

# ETSI EN 300 392-11-4 V1.1.1 (2003-07)

---

*European Standard (Telecommunications series)*

**Terrestrial Trunked Radio (TETRA);  
Voice plus Data (V+D);  
Part 11: Supplementary services stage 2;  
Sub-part 4: Call Forwarding (CF)**

---



---

Reference

DEN/TETRA-03001-11-04

---

Keywords

radio, TETRA

**ETSI**

650 Route des Lucioles  
F-06921 Sophia Antipolis Cedex - FRANCE

Tel.: +33 4 92 94 42 00 Fax: +33 4 93 65 47 16

Siret N° 348 623 562 00017 - NAF 742 C  
Association à but non lucratif enregistrée à la  
Sous-Préfecture de Grasse (06) N° 7803/88

---

**Important notice**

Individual copies of the present document can be downloaded from:

<http://www.etsi.org>

The present document may be made available in more than one electronic version or in print. In any case of existing or perceived difference in contents between such versions, the reference version is the Portable Document Format (PDF). In case of dispute, the reference shall be the printing on ETSI printers of the PDF version kept on a specific network drive within ETSI Secretariat.

Users of the present document should be aware that the document may be subject to revision or change of status. Information on the current status of this and other ETSI documents is available at

<http://portal.etsi.org/tb/status/status.asp>

If you find errors in the present document, send your comment to:

[editor@etsi.org](mailto:editor@etsi.org)

---

**Copyright Notification**

No part may be reproduced except as authorized by written permission.  
The copyright and the foregoing restriction extend to reproduction in all media.

© European Telecommunications Standards Institute 2003.  
All rights reserved.

**DECT™**, **PLUGTESTS™** and **UMTS™** are Trade Marks of ETSI registered for the benefit of its Members.  
**TIPHON™** and the **TIPHON logo** are Trade Marks currently being registered by ETSI for the benefit of its Members.  
**3GPP™** is a Trade Mark of ETSI registered for the benefit of its Members and of the 3GPP Organizational Partners.

# Contents

Intellectual Property Rights .....	6
Foreword.....	6
Introduction .....	7
1 Scope .....	8
2 References .....	8
3 Definitions and abbreviations.....	9
3.1 Definitions .....	9
3.2 Abbreviations .....	10
4 SS-CF specification.....	11
4.1 Case of re-routeing .....	11
4.1.1 Functional model .....	11
4.1.1.1 Functional model description .....	11
4.1.1.1.1 SS-CF management .....	11
4.1.1.1.2 SS-CF invocation counter.....	12
4.1.1.1.3 Individual calls .....	13
4.1.1.1.4 Group Calls.....	14
4.1.1.2 Description of the functional entities .....	17
4.1.1.2.1 Served user service agent, FE1 .....	17
4.1.1.2.2 Served user service control entity; call forwarding detection; SS-CF invocation counter initialize FE21 .....	17
4.1.1.2.3 SS-CF invocation counter execute, FE2x .....	17
4.1.1.2.4 Intermediate FE2x .....	17
4.1.1.2.5 Final FE2x .....	18
4.1.1.2.6 Served user/group activation, deactivation, enable, disable and interrogation control FE20 .....	18
4.1.1.2.7 Authorized user/group activation, deactivation, enable/disable and interrogation agent, FE3 .....	18
4.1.1.2.8 Calling user's service agent, FE5 .....	18
4.1.1.2.9 Calling user's service control entity; call forwarding by re-routeing execution entity, FE25.....	18
4.1.1.2.10 Forwarded-to user service agent, FE6 .....	18
4.1.1.2.11 Forwarded-to user service control entity, FE26.....	18
4.1.1.2.12 Group controlling entity, FE22.....	18
4.1.1.3 Relationship of functional model to basic call functional model .....	19
4.1.1.4 Relationship of functional model of SS-CF invocation counter to basic call functional model.....	20
4.1.1.5 Service primitives .....	20
4.1.2 Information flows .....	20
4.1.2.1 Definition of information flows .....	20
4.1.2.1.1 ACTIVATE information flow .....	20
4.1.2.1.2 ACTIVATE ACK information flow.....	21
4.1.2.1.3 DEACTIVATE information flow.....	21
4.1.2.1.4 DEACTIVATE ACK information flow .....	21
4.1.2.1.5 DISABLE information flow .....	22
4.1.2.1.6 DISABLE ACK information flow.....	22
4.1.2.1.7 ENABLE information flow .....	22
4.1.2.1.8 ENABLE ACK information flow .....	23
4.1.2.1.9 SS-CF invocation counter information flow.....	23
4.1.2.1.10 FORWARD information flow .....	23
4.1.2.1.11 FORWARD ACK information flow.....	23
4.1.2.1.12 INFORM2 information flow .....	23
4.1.2.1.13 INFORM4 information flow .....	24
4.1.2.1.14 INFORM5 information flow .....	24
4.1.2.1.15 INFORM8 information flow .....	24
4.1.2.1.16 INFORM9 information flow .....	25
4.1.2.1.17 INTERROGATE information flow .....	25
4.1.2.1.18 INTERROGATE ACK information flow.....	25

4.1.2.1.19	INTERROGATE2 information flow .....	25
4.1.2.1.20	INTERROGATE2 ACK information flow .....	26
4.1.2.1.21	REPORT INVOCATION information flow .....	26
4.1.2.2	Relationship of information flows to basic call information flows .....	26
4.1.2.3	Examples of information flow sequences .....	27
4.1.2.3.1	Case of individual call .....	28
4.1.2.3.2	Case of group call .....	43
4.1.3	Functional entity actions .....	47
4.1.3.1	Actions of FE1 .....	47
4.1.3.2	Actions of FE3 .....	47
4.1.3.3	Actions of FE5 .....	47
4.1.3.4	Actions of FE6 .....	47
4.1.3.5	Actions of FE20 .....	47
4.1.3.6	Actions of FE21 .....	48
4.1.3.7	Actions of FE22 .....	48
4.1.3.8	Actions at FE22C .....	49
4.1.3.9	Actions of FE25 .....	49
4.1.3.10	Actions of FE26 .....	49
4.1.3.11	Actions of FE2x .....	49
4.1.4	Functional entity behaviour .....	50
4.1.5	Allocation of functional entities to physical equipment .....	50
4.1.6	Interworking considerations .....	50
4.2	Case of forward switching .....	51
4.2.1	Functional model .....	51
4.2.1.1	Functional model description .....	51
4.2.1.1.1	SS-CF management .....	51
4.2.1.1.2	Individual Calls .....	51
4.2.1.2	Description of the functional entities .....	53
4.2.1.2.1	Calling user's service agent, FE5 .....	53
4.2.1.2.2	Calling user's service control entity, FE25 .....	53
4.2.1.2.3	Served user service control entity; call forwarding detection, FE21 .....	53
4.2.1.2.4	Served user service agent, FE1 .....	53
4.2.1.2.5	Forwarded-to user service control entity, FE26 .....	53
4.2.1.2.6	Forwarded-to user service agent, FE6 .....	53
4.2.1.2.7	Served user activation, deactivation and interrogation control, FE20 .....	53
4.2.1.2.8	Authorized user activation, deactivation and interrogation agent, FE3 .....	53
4.2.1.3	Relationship of functional model to basic call functional model .....	53
4.2.1.4	Service primitives .....	54
4.2.2	Information flows .....	54
4.2.2.1	Definition of information flows .....	54
4.2.2.2	Examples of information flow sequences .....	54
4.2.2.2.1	Information flow sequences for CFU/CFB operation .....	55
4.2.2.2.2	Information flow sequences for CFNRy operation .....	58
4.2.2.2.3	Information flow sequences for CFNRc operation .....	62
4.2.2.2.4	Information flow sequences for two stage forwarding, individual call, forward switching .....	66
4.2.2.2.5	Information flow sequences for SS-CF activation/deactivation .....	66
4.2.2.2.6	Information flow sequence for enabling/disabling of SS-CF authorized user activation/deactivation .....	67
4.2.2.2.7	Information flow sequence for SS-CF interrogation .....	67
4.2.3	Functional entity actions .....	67
4.2.3.1	Actions of FE1 .....	67
4.2.3.2	Actions of FE3 .....	67
4.2.3.3	Actions of FE5 .....	67
4.2.3.4	Actions of FE6 .....	67
4.2.3.5	Actions of FE20 .....	67
4.2.3.6	Actions of FE21 .....	67
4.2.3.7	Actions of FE25 .....	68
4.2.3.8	Actions of FE26 .....	68
4.2.4	Functional entity behaviour .....	69
4.2.5	Allocation of functional entities to physical equipment .....	69
4.2.6	Interworking considerations .....	69

**Annex A (informative): Bibliography.....70**  
History .....71

---

# Intellectual Property Rights

IPRs essential or potentially essential to the present document may have been declared to ETSI. The information pertaining to these essential IPRs, if any, is publicly available for **ETSI members and non-members**, and can be found in ETSI SR 000 314: *"Intellectual Property Rights (IPRs); Essential, or potentially Essential, IPRs notified to ETSI in respect of ETSI standards"*, which is available from the ETSI Secretariat. Latest updates are available on the ETSI Web server (<http://webapp.etsi.org/IPR/home.asp>).

Pursuant to the ETSI IPR Policy, no investigation, including IPR searches, has been carried out by ETSI. No guarantee can be given as to the existence of other IPRs not referenced in ETSI SR 000 314 (or the updates on the ETSI Web server) which are, or may be, or may become, essential to the present document.

---

## Foreword

This European Standard (Telecommunications series) has been produced by ETSI Project Terrestrial Trunked Radio (TETRA).

The present document had been submitted to Public Enquiry as ETS 300 392-11-4. During the processing for Vote it was converted into an EN.

The present document is part 11, sub-part 4 of a multi-part deliverable covering Voice plus Data (V+D), as identified below:

- EN 300 392-1: "General network design";
- EN 300 392-2: "Air Interface (AI)";
- EN 300 392-3: "Interworking at the Inter-System Interface (ISI)";
- ETS 300 392-4: "Gateways basic operation";
- EN 300 392-5: "Peripheral Equipment Interface (PEI)";
- EN 300 392-7: "Security";
- EN 300 392-9: "General requirements for supplementary services";
- EN 300 392-10: "Supplementary services stage 1";
- EN 300 392-11: "Supplementary services stage 2";**
  - ETS 300 392-11-1: "Call Identification (CI)";
  - ETS 300 392-11-2: "Call Report (CR)";
  - ETS 300 392-11-3: "Talking Party Identification (TPI)";
  - EN 300 392-11-4: "Call Forwarding (CF)";**
  - ETS 300 392-11-5: "List Search Call (LSC)";
  - ETS 300 392-11-6: "Call Authorized by Dispatcher (CAD)";
  - ETS 300 392-11-7: "Short Number Addressing (SNA)";
  - EN 300 392-11-8: "Area Selection (AS)";
  - ETS 300 392-11-9: "Access Priority (AP)";
  - EN 300 392-11-10: "Priority Call (PC)";
  - ETS 300 392-11-11: "Call Waiting (CW)";

- EN 300 392-11-12: "Call Hold (HOLD)";
- ETS 300 392-11-13: "Call Completion to Busy Subscriber (CCBS)";
- EN 300 392-11-14: "Late Entry (LE)";
- ETS 300 392-11-16: "Pre-emptive Priority Call (PPC)";
- EN 300 392-11-17: "Include Call (IC)";
- EN 300 392-11-18: "Barring of Outgoing Calls (BOC)";
- EN 300 392-11-19: "Barring of Incoming Calls (BIC)";
- ETS 300 392-11-20: "Discreet Listening (DL)";
- EN 300 392-11-21: "Ambience Listening (AL)";
- ETS 300 392-11-22: "Dynamic Group Number Assignment (DGNA)";
- ETS 300 392-11-23: "Call Completion on No Reply (CCNR)";
- ETS 300 392-11-24: "Call Retention (CRT)";
- EN 300 392-12: "Supplementary services stage 3";
- ETS 300 392-13: "SDL model of the Air Interface (AI)";
- ETS 300 392-14: "Protocol Implementation Conformance Statement (PICS) proforma specification";
- TS 100 392-15: "TETRA frequency bands, duplex spacing and channel numbering";
- TS 100 392-16: "Network Performance Metrics";
- TS 100 392-17: "TETRA V+D and DMO Release 1.1 specifications".

### National transposition dates

Date of adoption of this EN:	27 June 2003
Date of latest announcement of this EN (doa):	30 September 2003
Date of latest publication of new National Standard or endorsement of this EN (dop/e):	31 March 2004
Date of withdrawal of any conflicting National Standard (dow):	31 March 2004

## Introduction

Supplementary service specifications are produced in three stages, according to the method described in ITU-T Recommendation I.210 [2]. The present document contains the stage 2 specifications of SS-CFU, SS-CFB, SS-CFNRY and SS-CFNRC. The stage 2 specification identifies the functional entities involved in the supplementary services and the information flows between them.

The present document is based on the latest published text of ECMA-173 [1]. Additions/changes to ECMA-173 [1] have been made to take into account particular TETRA specifics such as group calls and to include situations such as "Not Reachable" not addressed in ECMA-173 [1].

NOTE 1: Contrary to ECMA-173 [1], the present document does not specify SS-CD (Call Deflection) which is not supported by TETRA.

NOTE 2: Contrary to ECMA-173 [1], the present document distinguishes between "No reply" and "Not reachable" because of the radio nature of the TETRA links.

---

# 1 Scope

The present document specifies the Call Forwarding supplementary services:

- Call Forwarding Unconditional (SS-CFU);
- Call Forwarding Busy (SS-CFB);
- Call Forwarding No Reply (SS-CFN<sub>Ry</sub>); and
- Call Forwarding Not Reachable (SS-CFN<sub>Rc</sub>);

which are applicable to various basic services supported by TETRA SwMIs. Basic services are specified in EN 300 392-2 [3].

SS-CFU, SS-CFB, SS-CFN<sub>Ry</sub> and SS-CFN<sub>Rc</sub> are supplementary services which apply during call establishment providing a forwarding of an incoming call to an other destination than the original destination defined by the called (served) user under different conditions (busy, no reply or not reachable respectively) or under no condition (unconditional).

The present document is applicable to circuit mode TETRA tele-services and bearer services only for all supplementary services specified in the present document. The present document applies also for SS-CFU to SDS (Short Data Services).

The present document also specifies the SS-CF invocation counter, which limits the number of call forwarding that a call request may encounter during call establishment, e.g. to protect the network against indefinite looping.

Man machine interfaces and charging principles are outside the scope of the present document.

---

# 2 References

The following documents contain provisions which, through reference in this text, constitute provisions of the present document.

- References are either specific (identified by date of publication and/or edition number or version number) or non-specific.
- For a specific reference, subsequent revisions do not apply.
- For a non-specific reference, the latest version applies.

Referenced documents which are not found to be publicly available in the expected location might be found at <http://docbox.etsi.org/Reference>.

- [1] ECMA-173: "Private Integrated Services Network (PISN) - Specification, Functional Model and Information Flows - Call Diversion Supplementary Services (CFSD)".
- [2] ITU-T Recommendation I.210: "Principles of telecommunication services supported by an ISDN and the means to describe them".
- [3] ETSI EN 300 392-2: "Terrestrial Trunked Radio (TETRA); Voice plus Data (V+D); Part 2: Air Interface (AI)".
- [4] ETSI EN 300 392-12-4: "Terrestrial Trunked Radio (TETRA); Voice plus Data (V+D); Part 12: Supplementary services stage 3; Sub-part 4: Call Forwarding (CF)".
- [5] ETSI EN 300 392-11-1: "Terrestrial Trunked Radio (TETRA); Voice plus Data (V+D); Part 11: Supplementary services stage 2; Call Identification (CI)".
- [6] ETSI EN 300 392-9: "Terrestrial Trunked Radio (TETRA); Voice plus Data (V+D); Part 9: General requirements for supplementary services".
- [7] ITU-T Recommendation Q.9: "Vocabulary of switching and signalling terms".



---

## 3 Definitions and abbreviations

### 3.1 Definitions

For the purposes of the present document the following terms and definitions apply:

**additional network feature:** capability, over and above that of a basic service, provided by a SwMI, but not directly to a SwMI user

**busy:** called user state if either a "network determined user busy" or a "user determined user busy" condition exists

**call, basic call:** instance of the use of a basic service

**connected number:** number of the user that answers (user C)

**forwarded-to number:** number to which a call is forwarded

**forwarded-to user:** user to which a call is forwarded

**forwarding:** redirection of a call, on behalf of a called user (served user, user B) and prior to answer, to a number different from the number of that called user

**forwarding counter:** number of call forwardings involved in a call or signalling connections during the establishment phase

**forwarding from alert:** type of forwarding invoked from an alerting state

NOTE: Forwarding from alert can occur as a result of the supplementary services CFNRy as specified in the present document.

**forwarding immediate:** type of forwarding invoked prior to reaching the alerting state

NOTE: Forwarding immediate can occur as a result of the supplementary services CFB and CFU as specified in the present document.

**forwarding number:** number of the served user (user B)

**forward switching:** network routing algorithm which performs the forwarding by joining together the first connection from user A's node to user B's node and a second, new connection from user B's node to user C's node

NOTE: In the TETRA SS-CF the connection is only implied as the communication path exists only after the completion of call forwarding.

**forwarding type:** parameter containing the reason for the forwarding: CFU, CFB, CFNRy, or CFNRc

**forwarding user:** user for which the call forwarding is invoked; it may be the first called user and then any of the successive forwarded-to users (see also last forwarding user)

**last forwarding user:** served user from the point of view of the forwarded-to user for a particular stage of call forwarding

NOTE: In the case of a call subject to a single stage of call forwarding, user B is the last forwarding user from the point of view of user C. In the case of a call subject to multiple stages of call forwarding, user B1 is the last forwarding user from the point of view of user B2, user B2 is the last forwarding user from the point of view of user B3, etc. The served user for the final stage of call forwarding is the last forwarding user from the point of view of user C.

**Mobile Station (MS):** physical grouping that contains all of the mobile equipment that is used to obtain TETRA services

NOTE: By definition, a mobile station contains at least one mobile radio stack.

**original called number:** number of user B (in case of multiple call forwarding user B1)

**original called user:** first served user of a call which is subject to one or more stages of call forwarding, i.e. user B or B1

**partial re-routeing:** network routeing algorithm which performs the call forwarding by replacing a particular part of the connection from user A's node to user B's node by another connection from user A's node to user C's node

NOTE: Partial re-routeing may be applicable only in the case of multiple call forwardings.

**re-routeing:** network routeing algorithm which performs the call forwarding by replacing the connection from user A's node to user B's node by another connection from user A's node to user C's node

**served user:** user whose calls to his number are forwarded. This user may also be referred to as the forwarding user or the called user or user B

**signalling connection:** connection used to exchange information between peer supplementary service protocol control entities independently of a basic call

**supplementary service:** any service provided by a network in addition to its basic service or services (defined in ITU-T Recommendation Q.9)

NOTE: A supplementary service modifies or supplements a basic telecommunication service. Consequently, it cannot be offered to a customer as a stand alone service. It must be offered together with or in association with a basic telecommunication service (excerpt from ITU-T Recommendation I.210 [2]).

**Switching and Management Infrastructure (SwMI):** all of the TETRA equipment for a Voice plus Data (V+D) network except for subscriber terminals

NOTE: The SwMI enables subscriber terminals to communicate with each other via the SwMI.

**tele-service:** type of telecommunications service that provides the complete capability, including terminal equipment functions, for communication between users according to agreed protocols

**user A:** user A is the calling user whose call is subject to call forwarding

**user B:** user B is the served (forwarding) user whose call is subject to call forwarding

**user B1, user B2, user B3, etc.:** These are the served (forwarding) users whose call is subject to multiple stages of forwarding. B1 is the first served user, B2 is the second served user, B3 is the third served user, etc.

NOTE: User B2 is also the forwarded-to user with respect to the first stage of call forwarding, B3 is also the forwarded-to user with respect to the second stage of call forwarding, etc.

**user C:** user C is the forwarded-to user with respect to the final stage of call forwarding.

## 3.2 Abbreviations

For the purposes of the present document, the following abbreviations apply:

ANF	Additional Network Feature
GTSI	Group TETRA Subscriber Identity
ISDN	Integrated Services Digital Network
ISI	Inter System Interface
ITSI	Individual TETRA Subscriber Identity
MS	Mobile Station
NDUB	Network Determined User Busy
PINX	Private Integrated services Network eXchange
SDL	Specification and Description Language
SS	Supplementary Service

NOTE: The abbreviation SS is only used when referring to a specific supplementary service.

SwMI	Switching and Management Infrastructure
TE	Terminal Equipment
UDUB	User Determined User Busy
V+D	Voice Plus Data

## Supplementary service abbreviations

For the purposes of the present document, the following abbreviations also apply:

CF	Call Forwarding
CFB	Call Forwarding on Busy
CFNRc	Call Forwarding on Not Reachable
CFNRy	Call Forwarding on No Reply
CFU	Call Forwarding Unconditional
CLIR	Calling Line Identification Restriction
COLP	COnnected Line Identification Presentation
IC	Include Call

---

## 4 SS-CF specification

This clause defines the stage 2 of the Call Forwarding supplementary services (CFU, CFB, CNFRy and CFNRc) using either the "re-routeing" network routeing algorithm, clause 4.1 or the "forward switching" network routeing algorithm, clause 4.2. The term CF used here indicates that unless otherwise noted, the specification applies to all four supplementary services.

Different types of call forwarding (e.g. CFU, CFB, CNFRy and CFNRc) may be concatenated during multiple call forwarding as well as different network routeing algorithms (call forwarding by "forward switching" and call forwarding by "re-routeing").

### 4.1 Case of re-routeing

#### 4.1.1 Functional model

##### 4.1.1.1 Functional model description

##### 4.1.1.1.1 SS-CF management

The functional model shall comprise the following Functional Entities (FEs) for managing SS-CF in the case where the authorized user is different from the served user:

- FE20: Served user/group home SwMI functional entity;
- FE3: Authorized user's functional entity;
- FE21: Call forwarding detection and control entity (at the served user current SwMI).

The relationship rx shall exist between FE3 and FE20 and the relationship ry shall exist between FE20 and FE21.

Figure 1 shows these FEs and relationship for the management part of SS-CF.



NOTE 1: In the case of local call forwarding in a visited SwMI, FE20 is the CF support entity in the current SwMI of the served user and is collocated with FE21 and route ry is internal to FE21.

NOTE 2: All requests issued by the authorized user for an SS-CF served user or group are to be addressed to the home SwMI of the served user or group. If the served user has migrated to another SwMI or if the group is linked with another group in other SwMIs than the group home SwMI, ANF-ISIMM will update these SwMIs. So there is no need to show any visited user visited SwMI FE.

**Figure 1: Functional entity model for the management part of SS-CF**

The functional model shall comprise the following Functional Entities (FEs) for managing SS-CF in the case where the authorized user is the served user:

- FE1: Served (authorized) user's functional entity;
- FE21: Call forwarding detection and control entity for the served user;

The relationship rx shall exist between FE1 and FE21.

Figure 2 shows these FEs and relationship for the management part of SS-CF.

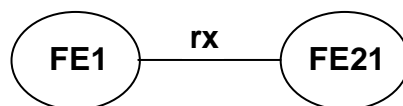

NOTE: All requests issued by the authorized user for an SS-CF served user or group are to be addressed to the home SwMI of this served user or group. If the served user has migrated to another SwMI or if the group is attached in other SwMIs than the group home SwMI, ANF-ISIMM will update these SwMIs. So there is no need to show any served user visited SwMI FE.

**Figure 2: Functional entity model for the management part of SS-CF**

In the case where the served user is not registered in its home SwMI, the functional model for the management part of SS-CF is modified as shown in figure 3.

- FE1: Served user's functional entity;
- FE20: Served user call forwarding management control entity;
- FE21: Call forwarding detection and control entity for the served user in the home SwMI;
- FE25: Served user's service support entity.

NOTE 1: In the operation of the CF the functional entity name FE25 is reused for calling user control entity.

In that case, relationships rz shall be added between the visited SwMI FE25 and FE20.

NOTE 2: This model allows the served user home SwMI to authorize or not a change of profile request by the served user when that user is in a visited SwMI different from home SwMI.

NOTE 3: While the figure 3 is shown with FE25 (most likely case), its extension to any visited SwMI different from the calling user SwMI is not excluded.

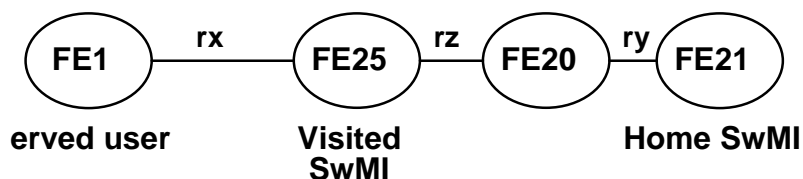

NOTE 1: In the case of local call forwarding, FE20 is collocated with FE21 and route ry is internal to FE21.

NOTE 2: This model holds only for the served/called user, not for any authorized user; this model holds only in the case where the called/served user is outside its home SwMI.

NOTE 3: This model holds independently of the routing mechanism, re-routing or forward switching.

**Figure 3: Functional entity model for the management part of SS-CF**

#### 4.1.1.1.2 SS-CF invocation counter

The functional model shall comprise the following functional entities:

- FE21: SS-CF invocation count initialize;
- FE2x: SS-CF invocation count execute.

The following functional relationship shall exist between these FEs:

- ra: between FE21 and FE2x and between consecutive FE2xs.

Figure 4 shows these FEs and relationship.

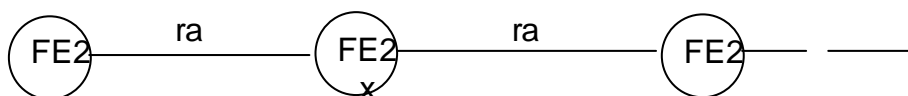

**Figure 4: Functional entity model for SS-CF counter**

#### 4.1.1.1.3 Individual calls

The functional model for individual calls shall comprise the following Functional Entities (FEs):

- FE5: Calling user's service agent;
- FE25: Calling user's service control entity; call forwarding control entity in the case of re-routeing;
- FE21: Call forwarding detection and control entity;
- FE1: Served user's service agent;
- FE26: Forwarded-to user's service control entity;
- FE6: Forwarded-to user's service agent.

The following functional relationships shall exist between these FEs:

- ra: between FE5 and FE25;
- rb: between FE25 and FE21;
- rc: between FE21 and FE1;
- rd: between FE25 and FE26;
- re: between FE26 and FE6;
- ry: between FE21 and FE20;
- rx: between FE20 and FE3.

Different types of call diversion (e.g. CFU, CFB, CFNRy and CFNRc) may be concatenated during multiple call diversion as well as different network routing algorithms (call diversion by "forward switching" and call diversion by "re-routeing").

#### 4.1.1.1.3.1 Single stage of call forwarding

Figure 5 shows the FEs and relationships for a single stage of call forwarding, individual call and re-routing. In the case of forward switching the FE21 will communicate directly with FE26 via route rf.

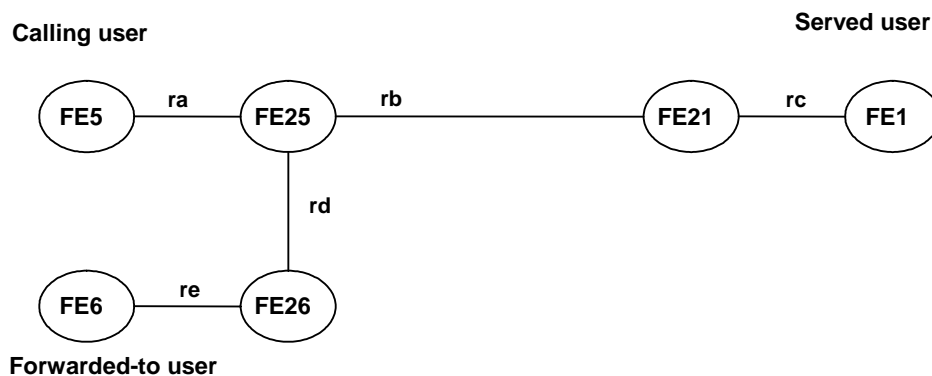

**Figure 5: Functional entity model for individual call, single stage of call forwarding and re-routing**

#### 4.1.1.1.3.2 Double stage of call forwarding

Figure 6 shows the FEs and relationships for two stages of call forwarding, individual call and re-routing.

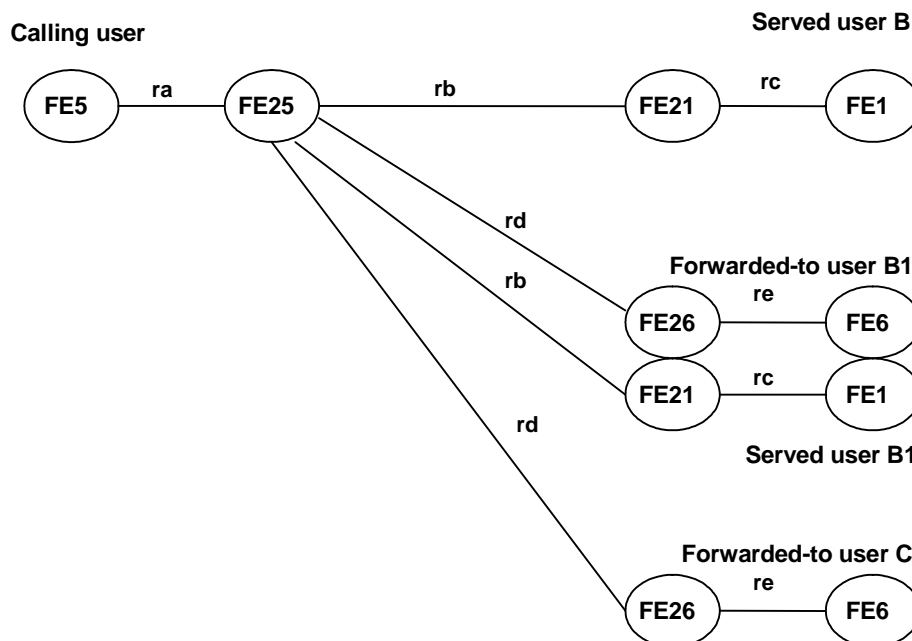

**Figure 6: Functional entity model for individual call, two stages of call forwarding and re-routing**

#### 4.1.1.1.4 Group Calls

The functional model for Group Calls shall comprise the following Functional Entities (FEs):

- FE5: Calling user's service agent;
- FE25: Calling user's service control entity; call forwarding control entity for re-routing;
- FE21: Call forwarding detection and control entity;
- FE1: Served user's service agent;
- FE26: Diverted-to user's service control entity;

- FE6: Diverted-to user's service agent;
- FE22: Group controlling Functional Entity;
- FE22B: Served group controlling Functional Entity (forwarding group);
- FE22C: Affected group controlling Functional Entity (forwarded-to group).

The following functional relationships shall exist between these FEs:

- ra: between FE5 and FE25;
- rb: between FE25 and FE22 (group call, re-routeing, one stage) or FE25 and FE22B (group call, re-routeing, two stages);
- rd: between either FE25 and FE26 in case of re-routeing (group call re-routed to an ITSI), FE25 and FE22C (B1, B2, etc.) in case of group call forwarded to another GTSI (case of re-routeing);
- re: between FE26 and FE6.

NOTE: Management routes rx and ry are the same as for individual calls.

#### 4.1.1.1.3.1 Group call, single stage of call forwarding, forwarding to another group

Figure 7 shows the FEs and relationships for a single stage of call forwarding, group call forwarded to another group GTSI and re-routeing.

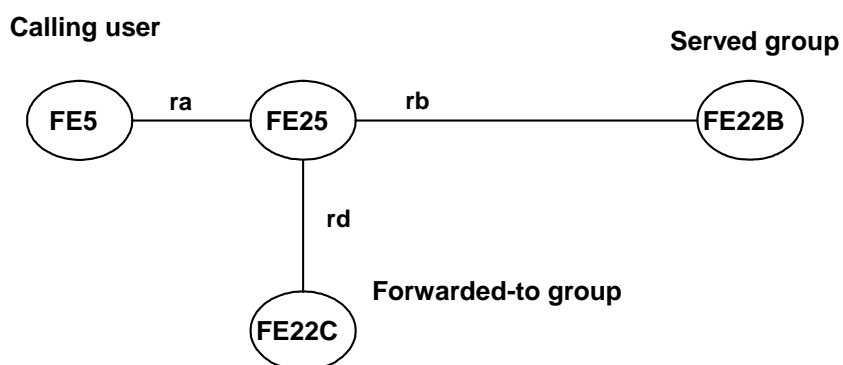

Figure 7: Functional entity model for group call, single stage of call forwarding and re-routeing

#### 4.1.1.1.3.2 Group call, single stage of call forwarding, forwarding to an ITSI

Figure 8 shows the FEs and relationships for a single stage of call forwarding, group call forwarded to an individual ITSI and re-routeing.

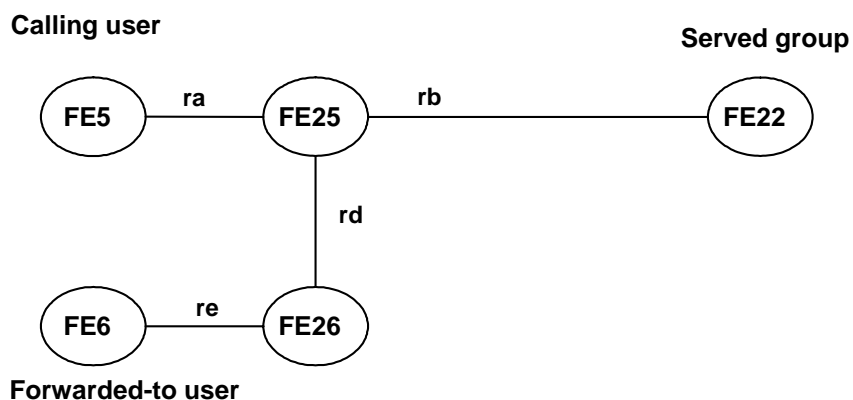
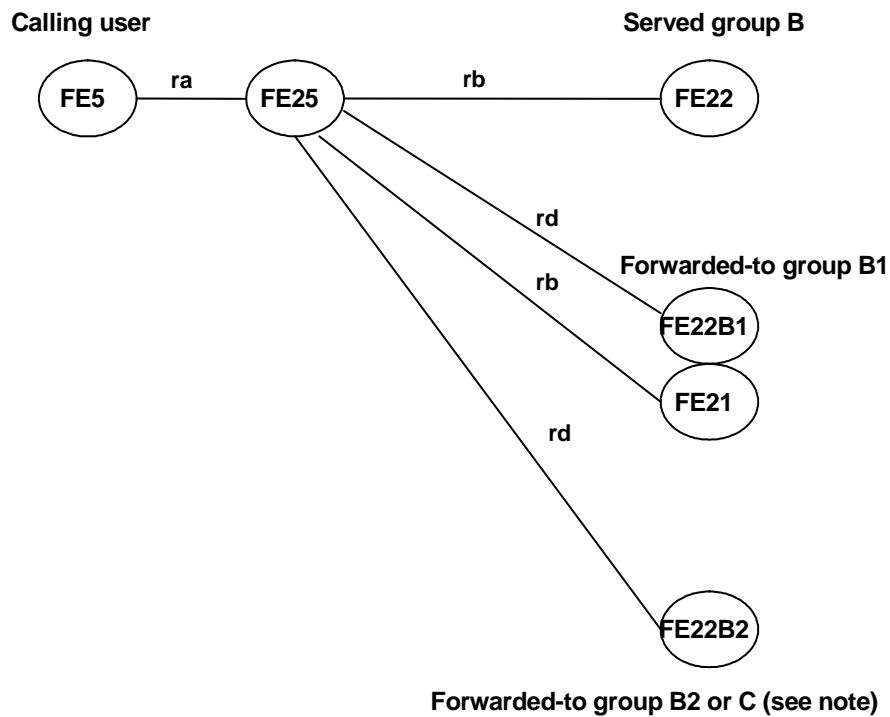

Figure 8: Functional entity model for group call, single stage of call forwarding (to an ITSI) and re-routeing

#### 4.1.1.1.3.3 Group call, double stage of call forwarding, forwarding to other groups

Figure 9 shows the FEs and relationships for two stages of call forwarding, group call forwarded to another group and re-routeing.



NOTE: C if last forwarded-to group.

**Figure 9: Functional entity model for group call, two stages of call forwarding and re-routeing towards a group**



#### 4.1.1.1.3.4 Group call, double stage of call forwarding, forwarding to an ITSI followed by forwarding to a group

Figure 10 shows the FEs and relationships for two stages of call forwarding, group call forwarded to an individual ITSI and re-routeing.

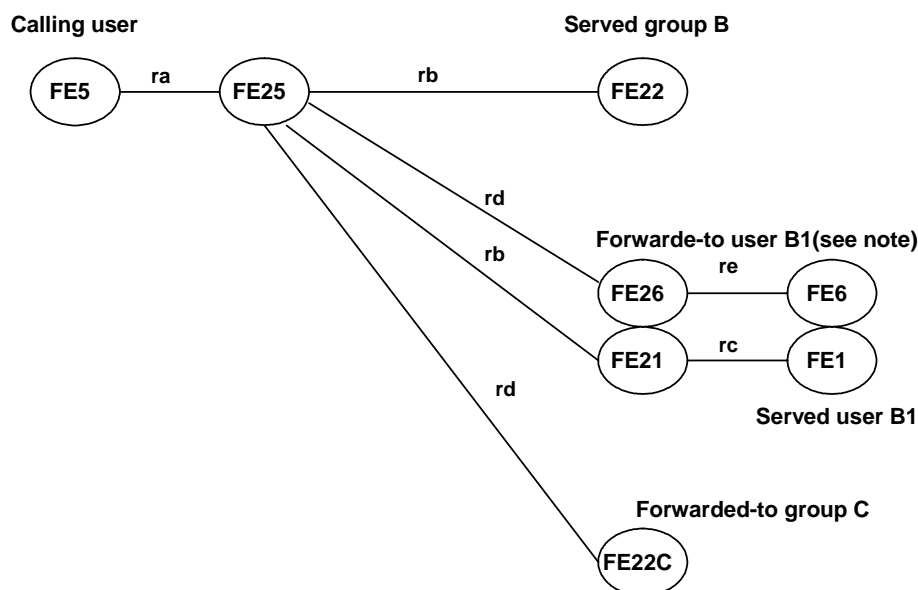

NOTE: The call to a group is assumed to be forwarded first to an individual user in this figure.

**Figure 10: Functional entity model for group call, two stages of call forwarding and re-routeing to an ITSI followed by call forwarding to a group**

#### 4.1.1.2 Description of the functional entities

##### 4.1.1.2.1 Served user service agent, FE1

This FE detects call forwarding activation/deactivation/enabling/disabling/interrogation requests from the served user and passes those requests to FE20 or FE21.

NOTE: "User determined user busy" UDUB is handled by the basic call and the FE1 in that sense is not needed for operational part of the SS-CF.

##### 4.1.1.2.2 Served user service control entity; call forwarding detection; SS-CF invocation counter initialize FE21

This FE detects a call forwarding request and supervises this request. FE21 provides a notification to FE25 and provides call forwarding information to FE25 in the case of re-routeing. FE 21 also receives activation, deactivation and interrogation requests from FE20 and provides responses to FE20. FE21 is responsible for modifying data related to activation, deactivation and authorized user activation/deactivation enabling and disabling. This FE also recognizes the invocation of SS-CF invocation counter, sets the SS-CF invocation counter to its initial value and passes it to FE2x.

##### 4.1.1.2.3 SS-CF invocation counter execute, FE2x

This FE receives the SS-CF invocation counter from FE21 or from another FE2x. The following two types of FE2x exist.

##### 4.1.1.2.4 Intermediate FE2x

An intermediate FE2x compares the SS-CF invocation counter to the allowed limit. If below the limit, FE2x increments the Ss-CF invocation counter and passes it to the next FE2; otherwise it requests rejection of the call request.

#### 4.1.1.2.5 Final FE2x

The final FE2x terminates the Ss-CF invocation counter actions.

#### 4.1.1.2.6 Served user/group activation, deactivation, enable, disable and interrogation control FE20

If the optional activation/deactivation procedure is supported by the home SwMI of the served user/group, FE20 shall receive SS-CF activation/deactivation requests from FE1 and FE3. FE20 shall then check them and if they are found authorized and correct, it shall make the definitions available to the relevant FE (FE21, FE25 or FE22) and shall confirm the completion of the service to FE1 or FE3 as appropriate. If not, FE20 shall reject the activation/deactivation request and inform the requesting FE.

The same shall apply for the optional interrogation procedure if they are supported by the home SwMI(s) of the served user(s)/group for these procedures.

The same shall apply for the optional enable/disable procedures for FE1 if they are supported by the home SwMI of the served user for these procedures.

#### 4.1.1.2.7 Authorized user/group activation, deactivation, enable/disable and interrogation agent, FE3

If the activation/deactivation and/or interrogation procedures are supported by the authorized user MS, FE3 shall send SS-CF activation/deactivation and/or interrogation requests to FE20. At the reception of the response from FE20, FE3 shall forward the result to the user application.

If the enable/disable procedures are supported in the home SwMI of the served user, then FE3 may receive enable/disable indications and shall pass those to the user.

NOTE: The authorized user may be either different or identical to the served user.

#### 4.1.1.2.8 Calling user's service agent, FE5

This optional FE delivers the call forwarding notifications to the calling user.

#### 4.1.1.2.9 Calling user's service control entity; call forwarding by re-routeing execution entity, FE25

This FE provides the appropriate call forwarding notifications to FE5 according to the information received from FE21, FE22 and/or FE26. In the case of re-routeing, this FE executes call forwarding by initiating a new call establishment, and requesting release of the leg to the original called user as defined for the basic call.

#### 4.1.1.2.10 Forwarded-to user service agent, FE6

This optional FE receives from FE26 call forwarding notifications and delivers them to the forwarded-to user.

#### 4.1.1.2.11 Forwarded-to user service control entity, FE26

This FE provides appropriate call forwarding notifications received from FE25 to FE6 using mechanisms defined in EN 300 392-9 [6].

#### 4.1.1.2.12 Group controlling entity, FE22

This FE fulfils the same functions as FE21 (case of re-routeing).

NOTE: The mode of operation defined for TETRA group call is re-routeing and only re-routeing.

### 4.1.1.3 Relationship of functional model to basic call functional model

Functional entity FE5 shall be collocated with calling user A's CCA.

Functional entity FE25 shall be collocated with calling user A's CC or with any incoming gateway CC or any Forwarding CC in the case of call forwarding by re-routing.

Functional entity FE21 shall be collocated with served user B's CC (users B1 ... Bn in case of multiple call forwarding) in the case of call forwarding by forward switching. Functional entity FE21 shall be collocated with served user B's CC in the case of re-routing.

Functional entity FE1 shall be collocated with served user B's CCA (users B1 ... Bn in case of multiple call forwarding) in the case of call forwarding by forward switching. Functional entity FE1 shall be collocated with served user B's CCA in the case of re-routing.

Functional entity FE26 shall be collocated with forwarded-to user C's CC, and also with the CCs for forwarded-to users B2 ... Bn in case of multiple call forwarding.

Functional entity FE6 shall be collocated with forwarded-to user C's CCA, and also with the CCAs for forwarded-to users B2 ... Bn in case of multiple call forwarding.

Functional entity FE22 shall be collocated with served group B's CC.

Being call unrelated, the activation/deactivation and interrogation procedures are independent from CC or CCA.

One example of the relationships with a basic service is shown in figure 11.

This example is used as the basis for the information flow sequence diagrams in clause 4.1.2.2.

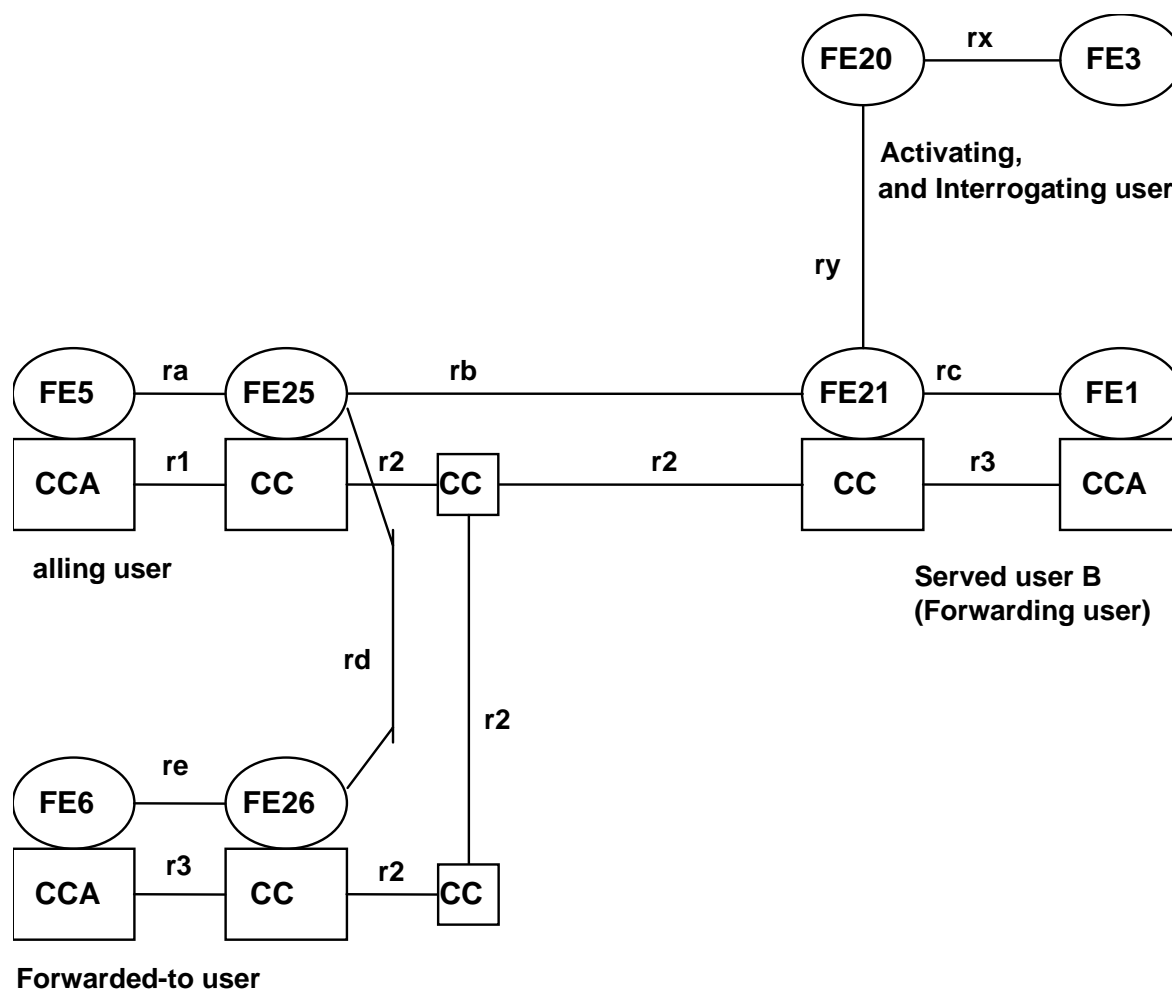

Figure 11: Functional Entity Model Relationship in Case of Individual Call, Single Stage Call Forwarding and Re-Routeing

#### 4.1.1.4 Relationship of functional model of SS-CF invocation counter to basic call functional model

FE21 shall be collocated with the originating CC, an incoming gateway CC, or a forwarding CC.

An intermediate FE2x shall be collocated with a transit CC.

The final FE2x shall be collocated with the terminating CC or an outgoing gateway CC.

Figure 12 shows an example of the relationship with the basic call functional model.

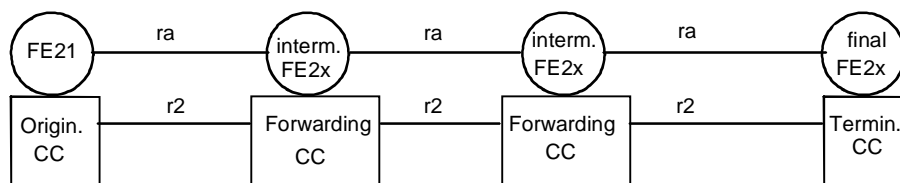

**Figure 12: Example relationship between models for ANF-CF and basic call**

#### 4.1.1.5 Service primitives

This clause lists SS-CF service primitives used to invoke or being a result of information flow sequences. The SS-CF service primitives are defined in EN 300 392-12-4 [4], clause 4.2 and the basic call service primitives are defined in EN 300 392-2 [3], clause 11.

### 4.1.2 Information flows

In the tables below, the column headed "Type" indicates which of the service elements are mandatory (M) and which are optional (O) in the corresponding information flow.

#### 4.1.2.1 Definition of information flows

##### 4.1.2.1.1 ACTIVATE information flow

This unconfirmed information flow activates call forwarding. It may be sent over relationships rx, relationship ry and relationship rz (in the case of individual call where the called user is not in its home SwMI) and it shall contain the service elements listed in table 1.

**Table 1: Contents of ACTIVATE information flow**

Service elements	Allowed value	Type
Forwarding type	CFU, CFB, CFNRy, CFNRc	M
Forwarded-to user number		M
Basic service information		M
Served user number		O (see note)
NOTE: This service element shall only be included in the case of activation by an authorized user different from the served user.		

#### 4.1.2.1.2 ACTIVATE ACK information flow

This unconfirmed information flow gives the result of the ACTIVATE information flow. It may be sent over relationship rx, relationship ry and relationship rz and it shall contain the service elements listed in table 2.

NOTE: This information flow is response to the ACTIVATE information flow.

**Table 2: Contents of ACTIVATE ACK information flow**

Service elements	Allowed value	Type
Forwarding type	CFU, CFB, CFNRy, CFNRc	M
Forwarded-to user number		M
Basic service information	any combination	M
Served user number		O (see note 1)
Activation request result	accepted/rejected	M
Cause for rejection	service not subscribed not authorized invalid forwarded-to user number specific SS-CFx service not subscribed Special service number not allowed invalid server user number temporarily unavailable	C (see note 2)
NOTE 1: This service element shall only be included in the case of activation by an authorized user different from the served user.		
NOTE 2: This service element shall only be included in case of rejection.		

#### 4.1.2.1.3 DEACTIVATE information flow

This unconfirmed information flow deactivates call forwarding. It may be sent over relationship rx, relationship ry and relationship rz and it shall contain the service elements listed in table 3.

**Table 3: Contents of DEACTIVATE information flow**

Service elements	Allowed value	Type
Served user number		O (see note)
NOTE: This service element shall only be included in the case of deactivation by an authorized user different from the served user.		

#### 4.1.2.1.4 DEACTIVATE ACK information flow

This unconfirmed information flow confirms and gives the result of the DEACTIVATE information flow. It may be sent over relationship rx, relationship ry and relationship rz and it shall contain the service elements listed in table 4.

NOTE: This information flow is response to the DEACTIVATE information flow.

**Table 4: Contents of DEACTIVATE ACK information flow**

Service elements	Allowed value	Type
Served user's number		C (see note 1)
Deactivation request result	accepted/rejected	M
Cause for rejection	service not subscribed not authorized invalid server user number part of the deactivation request failed temporarily unavailable	C (see note 2)
NOTE 1: This service element shall only be included in the case of deactivation by an authorized user different from the served user.		
NOTE 2: This service element shall only be included in case of rejection.		

## 4.1.2.1.5 DISABLE information flow

This unconfirmed information flow disables authorized user call forwarding activation. It may be sent over relationship rc and it shall contain the service elements listed in table 5.

**Table 5: Contents of DISABLE information flow**

Service elements	Allowed value	Type
Forwarding type	CFU, CFB, CFNRy, CFNRc	M
Basic service information	any combination	M
Authorized user number		M

## 4.1.2.1.6 DISABLE ACK information flow

This unconfirmed information flow confirms and gives result of the DISABLE information flow. It may be sent over relationship rc and it shall contain the service elements listed in table 6.

NOTE: This information flow is response to the DISABLE information flow.

**Table 6: Contents of DISABLE ACK information flow**

Service elements	Allowed value	Type
Forwarding type	CFU, CFB, CFNRy, CFNRc	M
Basic service information	any combination	M
Authorized user number		M
Disable request result	accepted/rejected	M
Cause for rejection	service not subscribed not authorized invalid authorized user number temporarily unavailable	C (see note)
NOTE: This service element shall only be included in case of rejection.		

## 4.1.2.1.7 ENABLE information flow

This unconfirmed information flow enables authorized user call forwarding activation. It may be sent over relationship rc and it shall contain the service elements listed in table 7.

**Table 7: Contents of ENABLE information flow**

Service elements	Allowed value	Type
Forwarding type	CFU, CFB, CFNRy, CFNRc	M
Basic service information	any combination	M
Authorized user number		M

#### 4.1.2.1.8 ENABLE ACK information flow

This unconfirmed information flow confirms and gives the result of the ENABLE information flow. It may be sent over relationship rc and it shall contain the service elements listed in table 8.

NOTE: This information flow is response to the ENABLE information flow.

**Table 8: Contents of ENABLE ACK information flow**

Service elements	Allowed value	Type
Forwarding type	CFU, CFB, CFNRy, CFNRc	M
Basic service information	any combination	M
Authorized user number		M
Enable request result	accepted/rejected	M
Cause for rejection	service not subscribed not authorized invalid authorized user number	C (see note)
NOTE: This service element shall only be included in case of rejection.		

#### 4.1.2.1.9 SS-CF invocation counter information flow

SS-CF invocation counter is an unconfirmed information flow across ra from FE21 to FE2x and between FE2xs.

Table 9 lists the service elements within the SS-CF invocation counter information flow.

**Table 9: Content of SS-CF invocation counter information flow**

Service element	Allowed Value	Request
Forwarding count	Integer (see note)	M
NOTE: The allowed range is (0, ..., max) where max is a network dependent maximum value.		

#### 4.1.2.1.10 FORWARD information flow

This unconfirmed information flow is a basic call information flow that invokes call forwarding operation, refer to ISI-INFORM1 request (ISI-REDIRECT PDU). The FORWARD information flow is included in the present document only for historical reasons.

#### 4.1.2.1.11 FORWARD ACK information flow

This unconfirmed information flow is a basic call information flow that gives the result of the invocation of the call forwarding operation, refer to ISI-INFORM1 request (ISI-REDIRECT PDU). The FORWARD ACK information flow is included in the present document only for historical reasons.

#### 4.1.2.1.12 INFORM2 information flow

This optional unconfirmed information flow indicates to FE5 that call forwarding has been initiated. It shall be sent over relationship rd.

The INFORM2 shall contain service elements as defined in table 10.

**Table 10: Content of INFORM2 information flow**

Service elements	Allowed value	Type
Forwarding type	CFU, CFB, CFNRy, CFNRc	M

## 4.1.2.1.13 INFORM4 information flow

This unconfirmed information flow indicates to FE26 that call forwarding is taking place. It shall be sent over relationship rd and it shall contain the service elements listed in table 11.

Table 11: Content of INFORM4 information flow

Service elements	Allowed value	Type
Last forwarding type	CFU, CFB, CFNRy, CFNRc	M
Last forwarding user identity presentation	Presentation allowed Presentation not allowed	M
Last forwarding number		O (see notes 1 and 2)
Original forwarding type	CFU, CFB, CFNRy, CFNRc	O
Original forwarding user identity presentation		M
Original called number		O (see note 1)
NOTE 1: This service element shall be present, if the presentation is allowed, and may be present, if presentation is not allowed.		
NOTE 2: This service element shall only be included in case of multiple forwarding.		

## 4.1.2.1.14 INFORM5 information flow

This optional unconfirmed information flow indicates to FE6 that call forwarding is taking place. It may be sent over relationship re and it shall contain the service elements listed in table 12.

NOTE: Instead of or in addition to the INFORM 5 information flow the Notification indicator information flow of the basic call may be used.

Table 12: Content of INFORM5 information flow

Service elements	Allowed value	Type
Original forwarding type	CFU, CFB, CFNRy, CFNRc	M
Original called user number		O (see notes 1 and 2)
Last forwarding type	CFU, CFB, CFNRy, CFNRc	O (see note 1)
Last forwarding user number		O (see note 2)
NOTE 1: This service element shall only be included in case of multiple forwarding.		
NOTE 2: This service element shall only be included if no restriction exists.		

## 4.1.2.1.15 INFORM8 information flow

This optional unconfirmed information flow indicates to FE1 that CFU/CFB/CFNRy/CFNRc has been activated. It shall be sent over relationship rc and it shall contain the service elements listed in table 13.

Table 13: Contents of INFORM8 information flow

Service elements	Allowed value	Type
Forwarding Type	CFU, CFB, CFNRy, CFNRc	M
Forwarded-to number		M
Basic service information	speech, data, SDS or any combination of those	M



## 4.1.2.1.16 INFORM9 information flow

This optional unconfirmed information flow indicates to FE1 that CFU/CFB/CFNRy/CFNRc has been deactivated. It shall be sent over relationship rc and it shall contain the service elements listed in table 14.

Table 14: Contents of INFORM9 information flow

Service elements	Allowed value	Type
Forwarding Type	CFU, CFB, CFNRy, CFNRc	M
Basic Service	speech, data, SDS or any combination of those	M

## 4.1.2.1.17 INTERROGATE information flow

This unconfirmed information flow conveys call forwarding interrogation. It may be sent over relationship rx, ry and rz and it shall contain the service elements listed in table 15.

Table 15: Contents of INTERROGATE information flow

Service elements	Allowed value	Type
Served user number		M (see note)
NOTE: This service element shall only be included in the case of interrogation by an authorized user different from the served user.		

## 4.1.2.1.18 INTERROGATE ACK information flow

This unconfirmed information flow conveys call forwarding interrogation. It may be sent over relationship rx and relationship ry and it shall contain the service elements listed in table 16.

Table 16: Contents of INTERROGATE ACK information flow

Service elements	Allowed value	Type
Forwarding type	CFU, CFB, CFNRy, CFNRc	M
Basic service information	speech, data, SDS or any combination of those	M
Served user number		O (see note 1)
Interrogation request result	accepted service not subscribed not authorized invalid served user number temporarily unavailable	M
Forwarded-to number		O (see note 2)
Enabled authorized User		O (see note 2)
NOTE 1: This service element shall only be included in the case of interrogation by an authorized user different from the served user.		
NOTE 2: This service element shall only be included if call forwarding is activated. It may be repeated.		

## 4.1.2.1.19 INTERROGATE2 information flow

This unconfirmed information flow conveys call forwarding interrogation. It may be sent over relationship rx, ry and rz and it shall contain the service elements listed in table 17.

Table 17: Contents of INTERROGATE2 information flow

Service elements	Allowed value	Type
Forwarding Type	CFU, CFB, CFNRy, CFNRc	M
Basic Service	speech, data, SDS or any combination of those	M

#### 4.1.2.1.20 INTERROGATE2 ACK information flow

This unconfirmed information flow conveys call forwarding interrogation2 acknowledgement. It may be sent over relationship rx, ry and rz and it shall contain the service elements listed in table 18.

**Table 18: Contents of INTERROGATE2 ACK information flow**

Service elements	Allowed value	Type
Interrogation result	accepted service not subscribed not authorized invalid served user number temporarily unavailable	M
Served user number		O
Forwarding Type	CFU, CFB, CFNRy, CFNRc	O
Basic Service	speech, data, SDS or any combination of those	O

#### 4.1.2.1.21 REPORT INVOCATION information flow

This unconfirmed information flow conveys call forwarding invocation notification only in the case where called/served user is outside its home SwMI. It may be sent over relationship rb and it shall contain the service elements listed in table 19.

**Table 19: Contents of REPORT INVOCATION information flow**

Service elements	Allowed value	Type
Forwarding type	CFU, CFB, CFNRy, CFNRc	M
Basic service	speech, data, SDS or any combination of those	M
Served user's number		O
Served user visited MNI		O
Forwarded-to number		O

#### 4.1.2.2 Relationship of information flows to basic call information flows

The SS-CF invocation counter information flow shall be sent across ra in conjunction with the basic ISI-IC-SETUP request sent to establish a call.

The SS-CF INFORM 4 Indication information flow shall be sent across re in conjunction with ISI-IC-SETUP request/indication call is being forwarded.

The SS-CF INFORM 5 Indication information flow shall be sent across rf in conjunction with D-SETUP request/indication to indicate that call has been forwarded.

Table 20 summarizes the relationship of the SS-CF information flows to those of basic call.

**Table 20: Relationship of SS-CF information flows to basic call**

Information flow	Independent of basic call?	With basic call flow?	Basic call flows:
ACTIVATE	YES	NO	
ACTIVATE ACK	YES	NO	
DEACTIVATE	YES	NO	
DEACTIVATE ACK	YES	NO	
DISABLE	YES	NO	
DISABLE ACK	YES	NO	
ENABLE	YES	NO	
ENABLE ACK	YES	NO	
SS-CF INVOCATION COUNTER	NO	YES	ISI-IC-SETUP (see note)
FORWARD	YES	NO	
FORWARD ACK	YES	NO	
INFORM 2	YES	NO	
INFORM 4	NO	YES	ISI-IC-SETUP (see note)
INFORM 5	NO	YES	D-SETUP
INFORM 8	YES	NO	
INFORM 9	YES	NO	
INTERROGATE	YES	NO	
INTERROGATE ACK	YES	NO	
REPORT INVOCATION	YES	NO	(see note)
NOTE: On ISI only.			

#### 4.1.2.3 Examples of information flow sequences

Signalling procedures shall be provided in support of the information flow sequences specified below. In addition, signalling procedures should be provided to cover other sequences arising from error situations, interactions with basic call, interactions with other supplementary services, different topologies, etc. Refer to EN 300 392-12-4 [4].

In the figures, SS-CF information flows are represented by solid arrows and basic call information flows are represented by broken arrows. An ellipse embracing two information flows indicates that the two information flows occur together. Within a column representing an SS-CF functional entity, the numbers refer to functional entity actions listed in clause 4.3.

Basic call information flows are represented only as far as necessary for the understanding of the SS-CF procedures.

NOTE 1: In the information flow in clauses 4.1.2.2.1 and 4.1.2.2.2 FORWARD and FORWARD ACK information flows are replaced by basic call information flow and are shown only for historic reasons.

NOTE 2: In the information flow in clauses 4.1.2.2.1 and 4.1.2.2.2 INFORM 6 and INFORM 7 information flows are SS-CI [5] information flows and are shown only for historic reasons.

4.1.2.3.1 Case of individual call

4.1.2.2.1.1 Information flow sequences for CFU/CFB operation

The information flow sequence for successful CFU/CFB operation is shown in figure 13. The case of SS-CFB for NDUB lead to the same information flows.

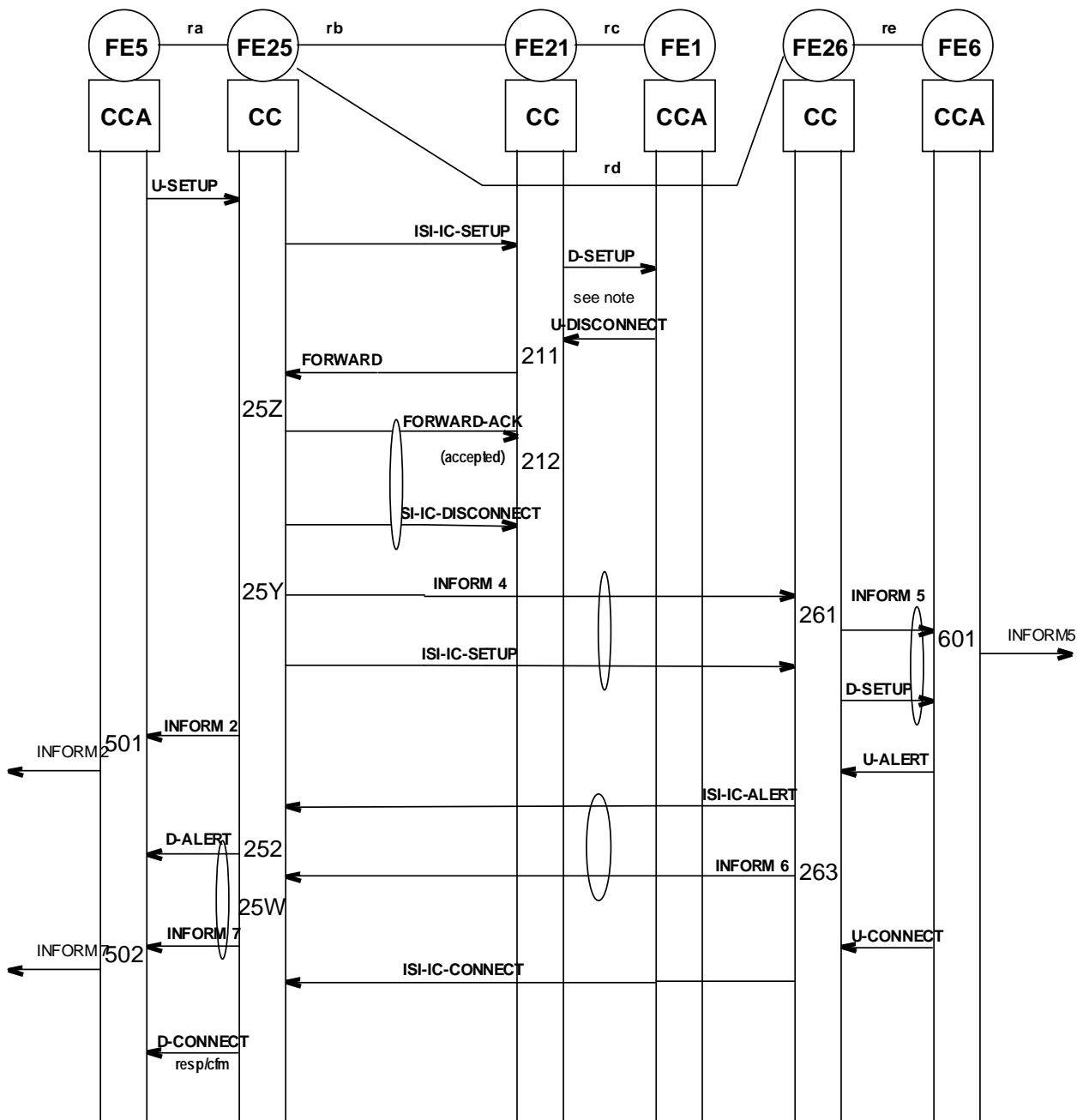

NOTE: This information flow is only applicable in case of CFB-UDUB.

Figure 13: Information flow sequence for successful CFU/CFB operation; case of re-routing

The information flow sequences for unsuccessful CFU/CFB operation are shown in figures 14 and 15.

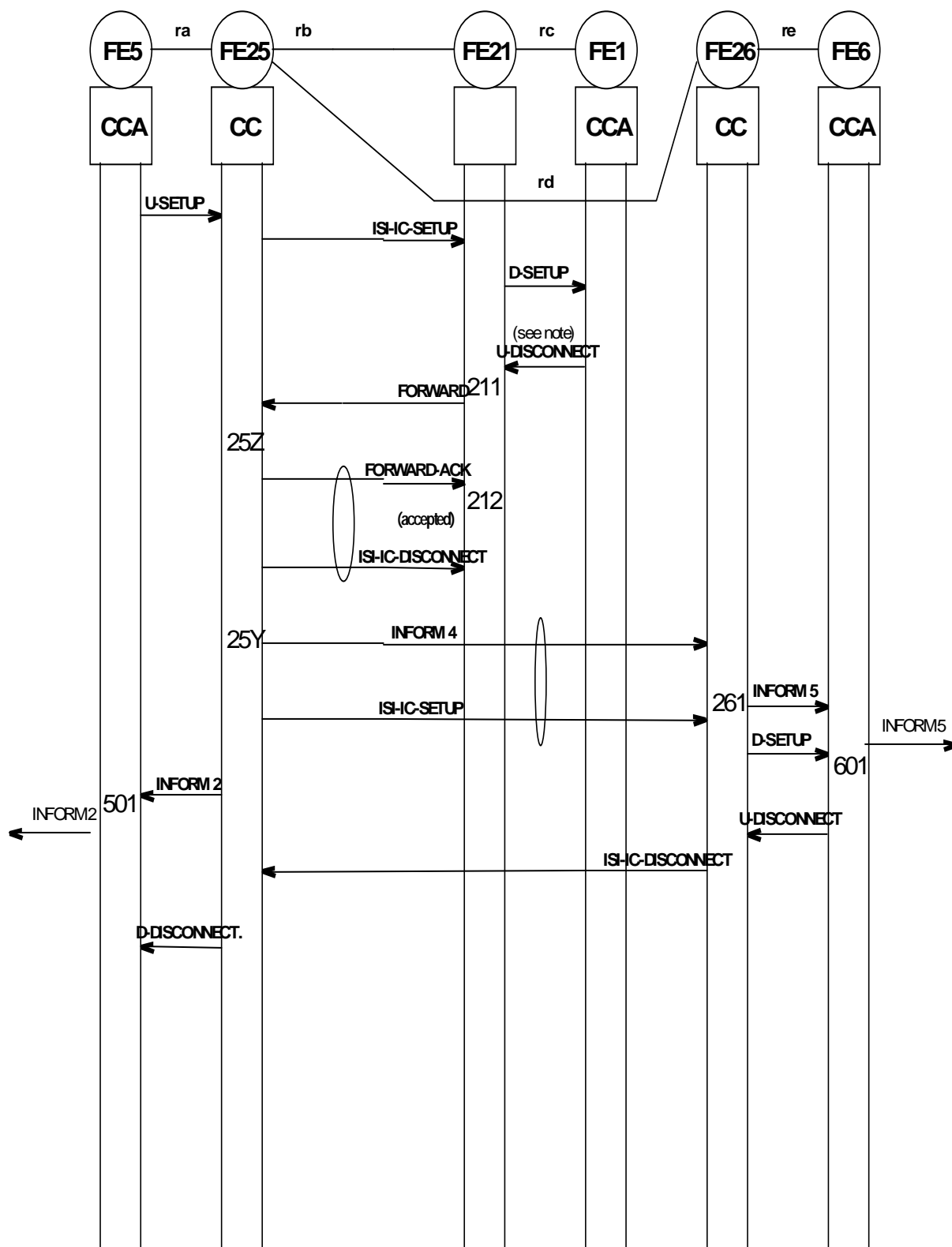

NOTE: This information flow is only applicable in case of CFB-UDUB.

Figure 14: Information flow sequence for unsuccessful CFU/CFB operation: failure of forwarded call; case of re-routing

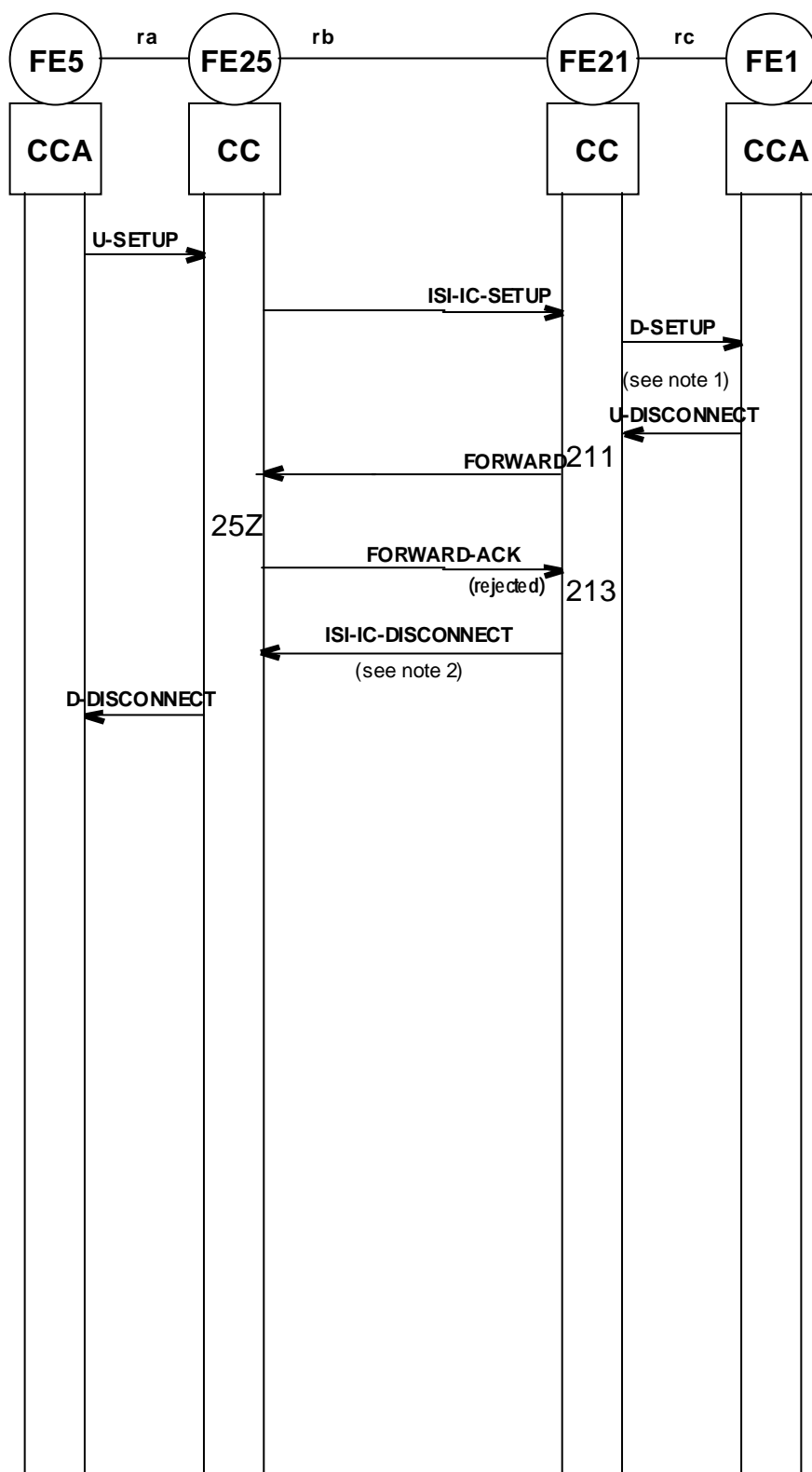

NOTE 1: This information flow is only applicable in case of CFB-UDUB.

NOTE 2: With a disconnect cause unsuccessful call forwarding.

**Figure 15: Information flow sequences for unsuccessful CFU/CFB operation: rejection of call forwarding; case of re-routing**

In the case where the called/served user is outside home SwMI, the following additional information flow shall take place as shown in figure 16.

NOTE: The other information flows are unaffected by this information flow.

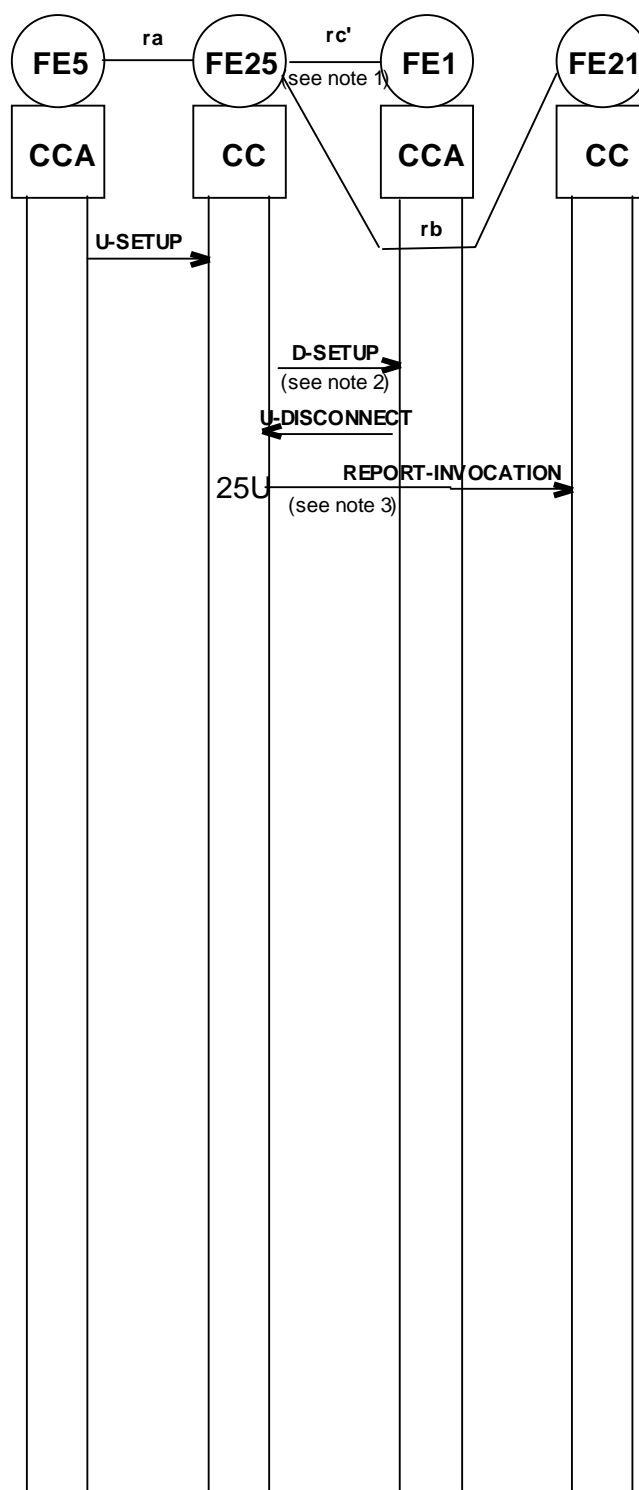

NOTE 1: The served user is in FE25.

NOTE 2: This information flow is only applicable in case of CFB-UDUB.

NOTE 3: The information flow "REPORT INVOCATION" is sent regardless of the final outcome of SS-CF by the served user visited SwMI.

**Figure 16: Information flow sequences for SS-CF invocation outside home SwMI of called/served user**

4.1.2.2.1.2 Information flow sequences for CFNRy operation

The information flow sequence for successful CFNRy operation is shown in figure 17.

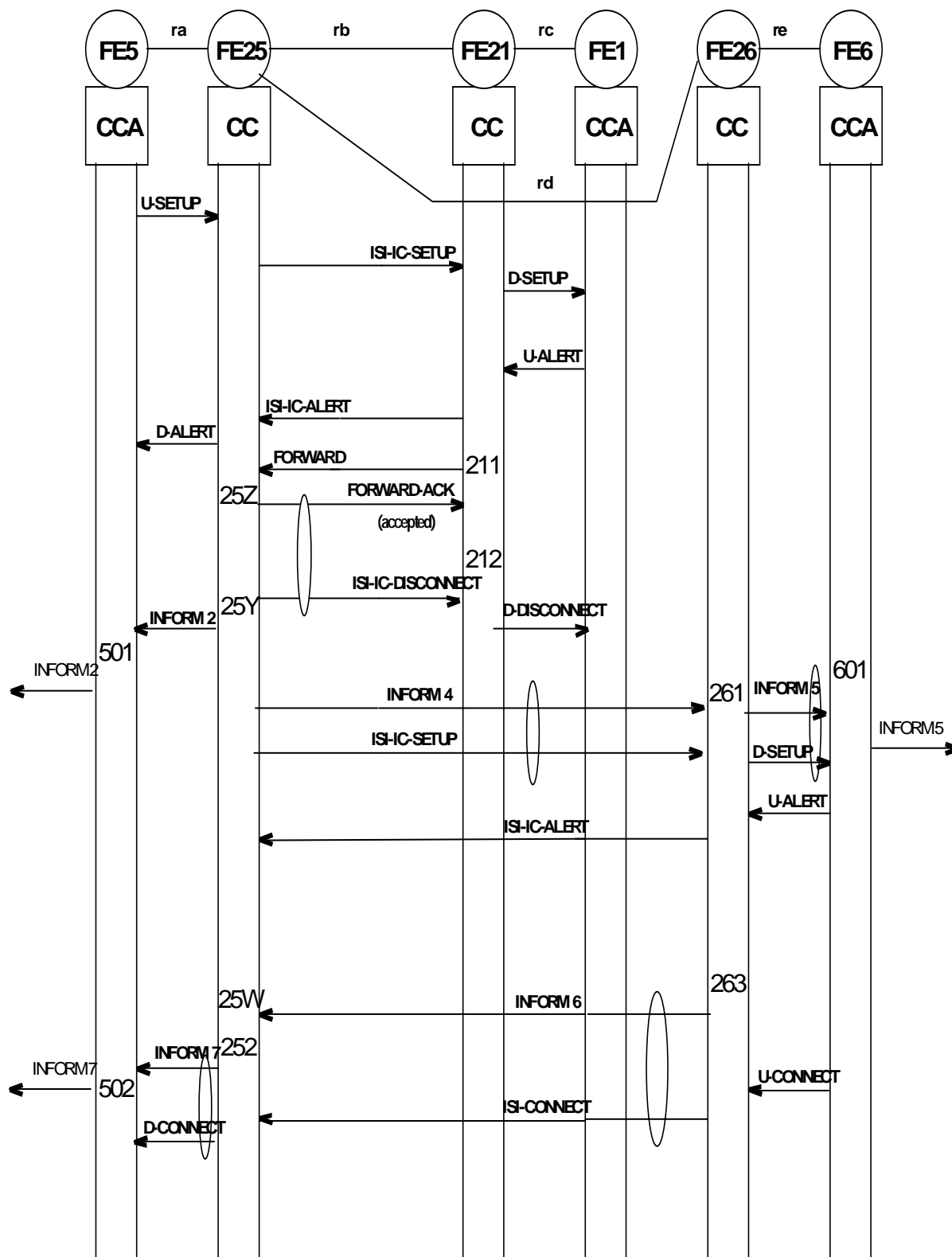

Figure 17: Information flow sequence for successful CFNRy operation; case of re-routeing



The information flow sequence for clearing by user A during CFNRy operation is shown in figure 18.

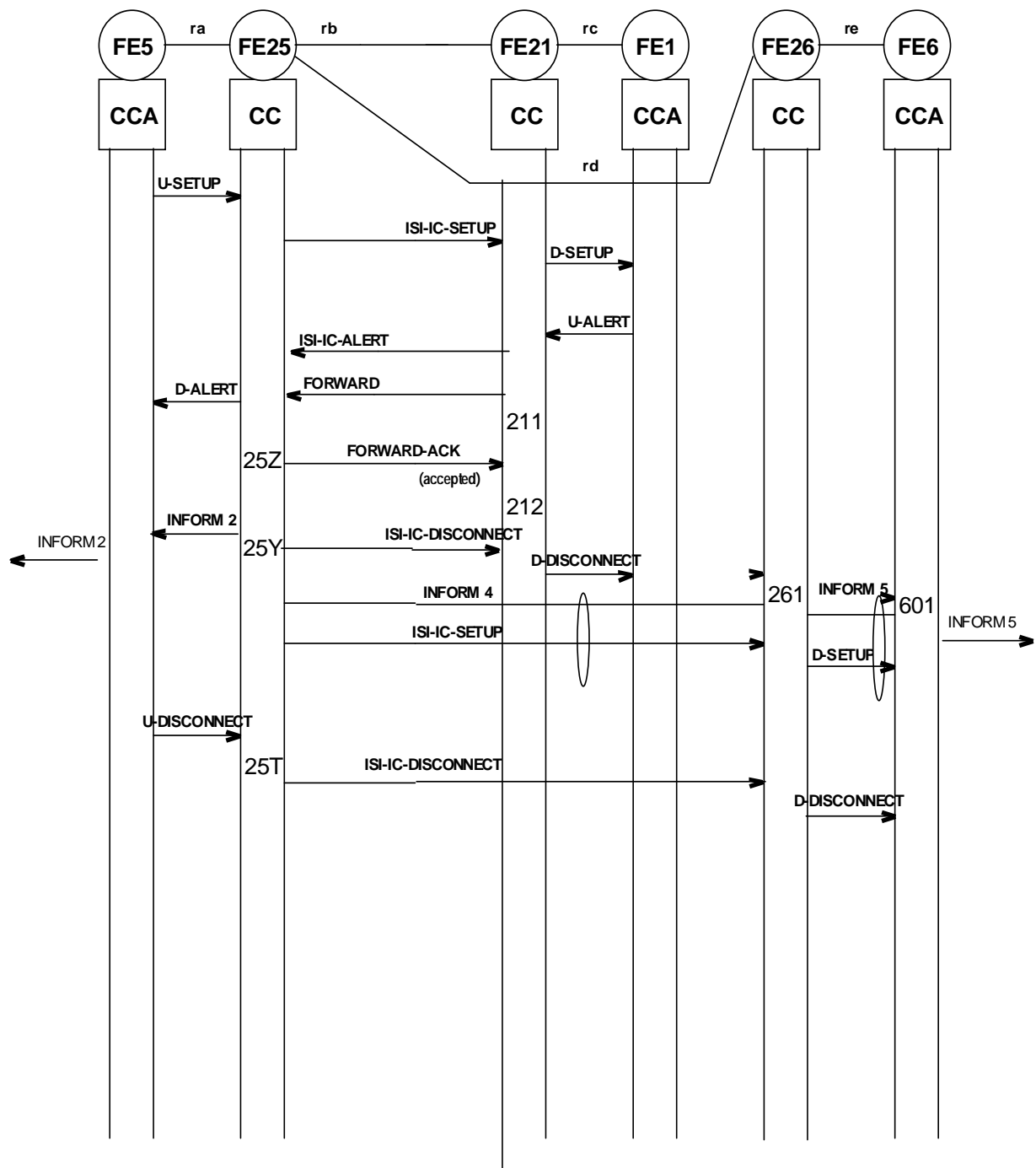

Figure 18: Information flow sequence for clearing by user A during CFNRy operation; case of re-routing

The information flow sequences for unsuccessful CFNRy operation are shown in figures 19 and 20.

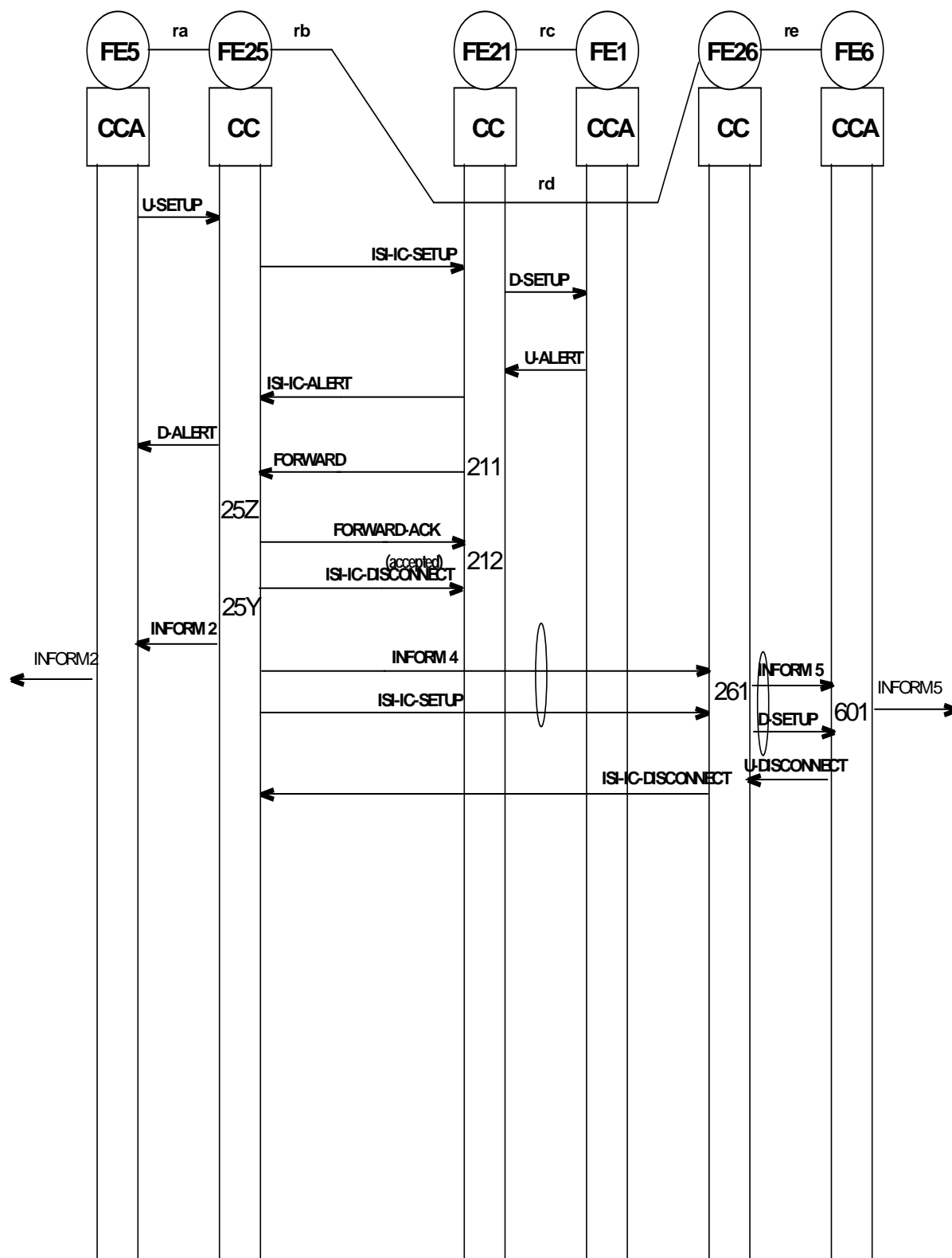
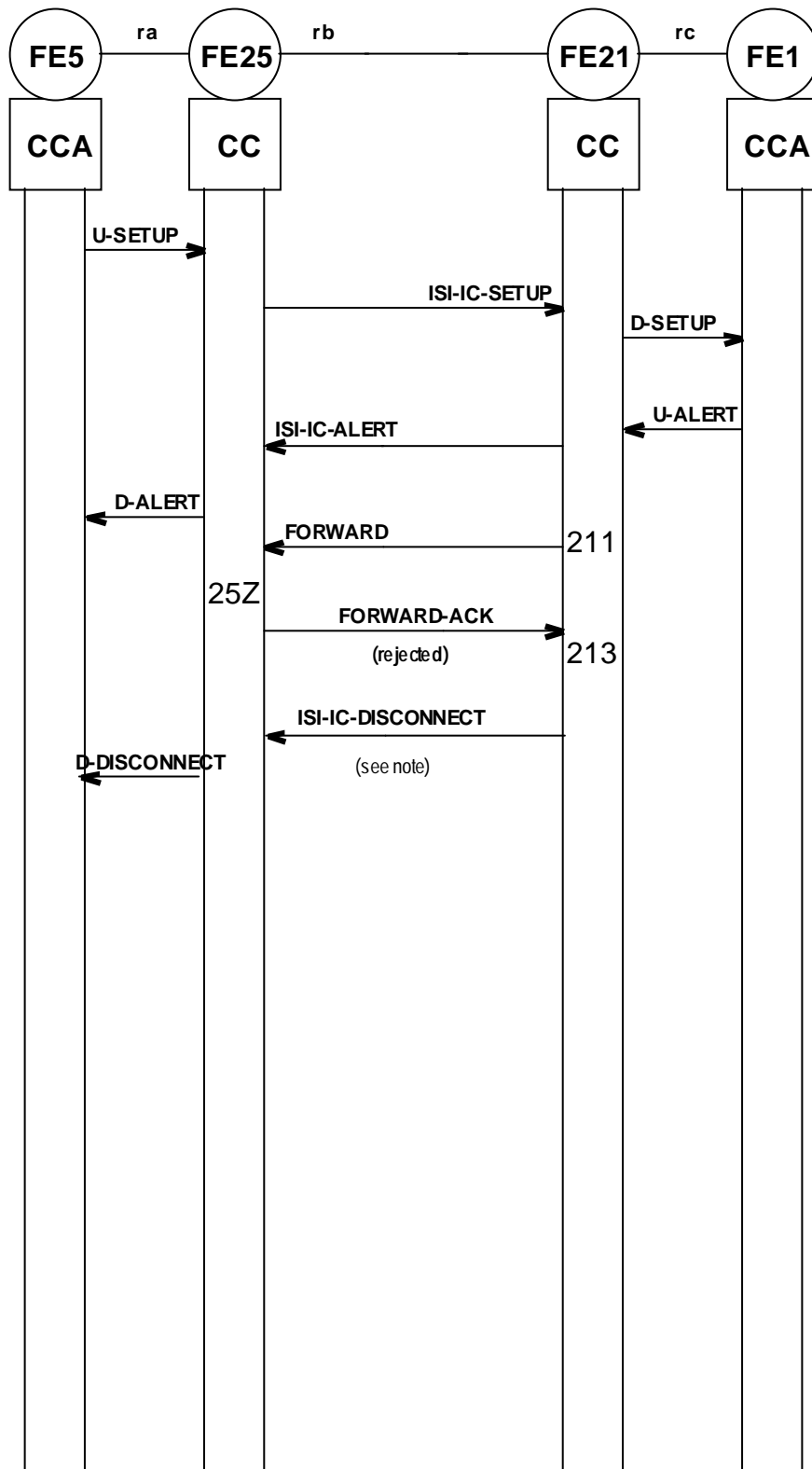

Figure 19: Information flow sequences for unsuccessful CFNRy operation: CFNRy not completed, original call cleared; case of re-routing



NOTE: With a disconnect cause "SS-specific disconnection".

**Figure 20: Information flow sequences for unsuccessful CFNRy operation:  
CFNRy rejected, original call cleared; case of re-routing**

4.1.2.2.1.3 Information flow sequences for CFNRc operation

The information flow sequence for successful CFNRc operation is shown in figure 21.

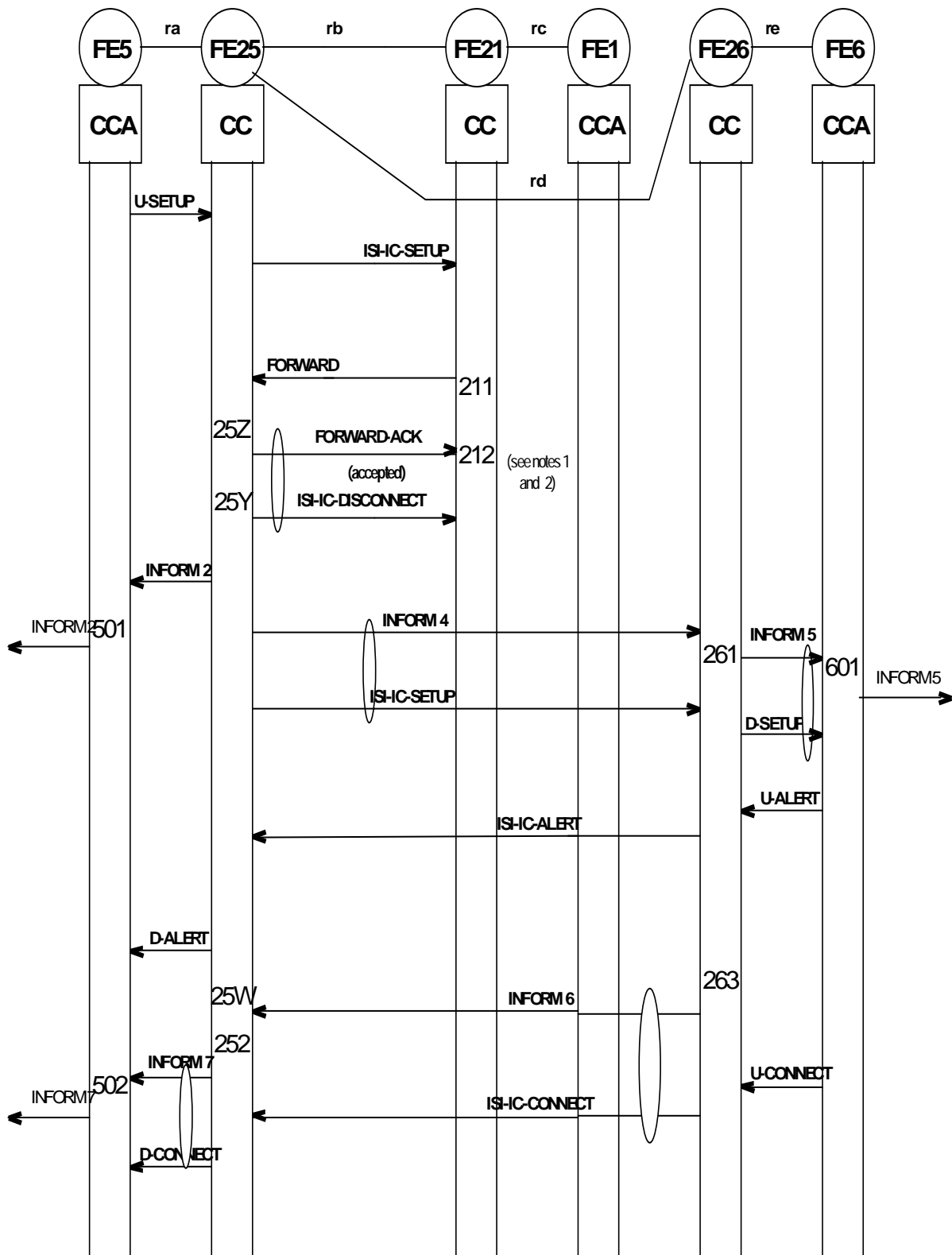

NOTE 1: There is no INFORM information flow towards FE1 since it is in a not reachable status.  
 NOTE 2: It is assumed that FE1 is not reachable at the invocation of SS-CF.

Figure 21: Information flow sequence for successful CFNRc operation; case of re-routing

The information flow sequence for clearing by user A during CFNRc operation is shown in figure 22.

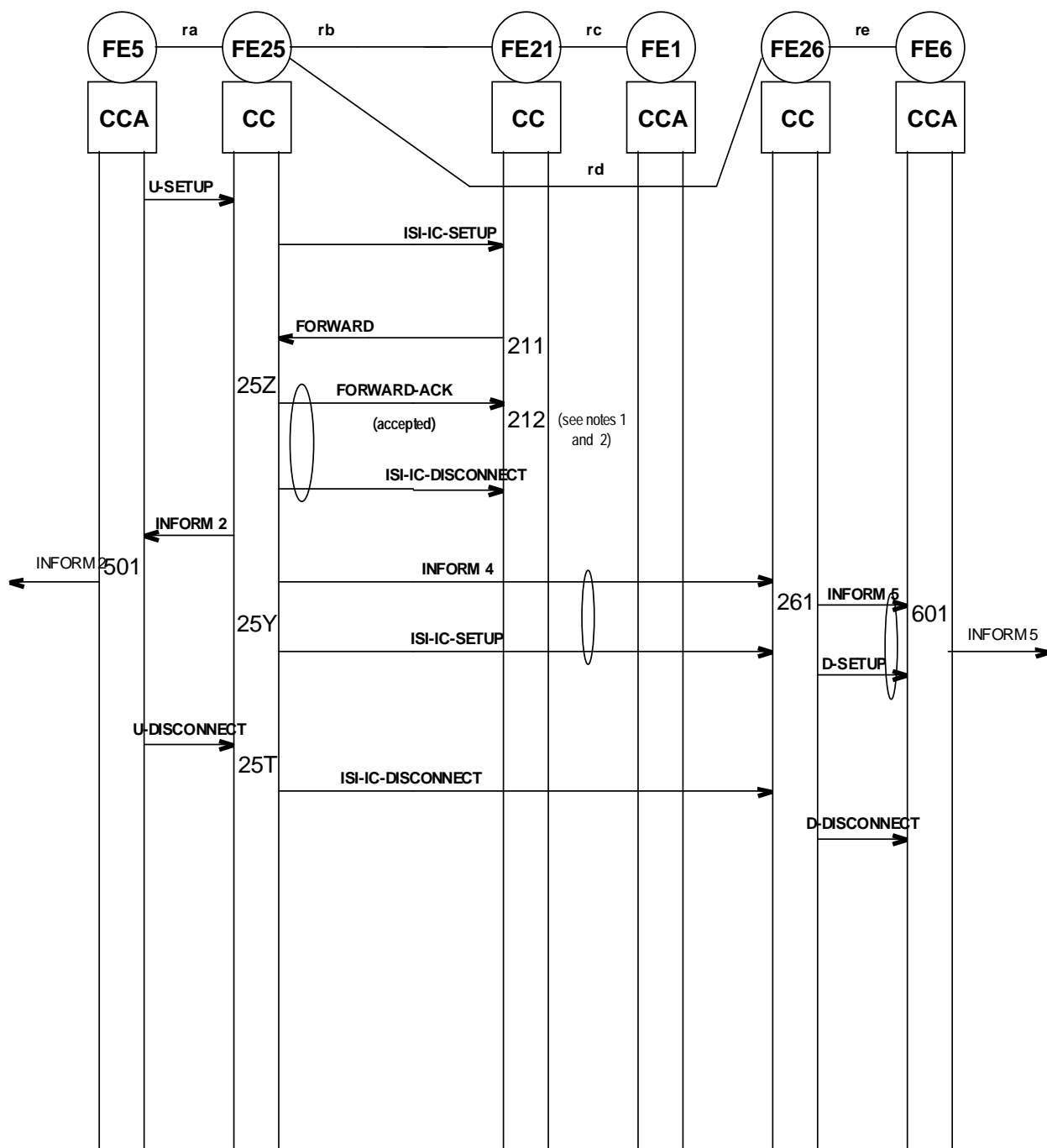

NOTE 1: There is no INFORM information flow towards FE1 since it is in a not reachable status.

NOTE 2: It is assumed that FE1 is not reachable at the invocation of SS-CF.

**Figure 22: Information flow sequence for clearing by user A during CFNRc operation; case of re-routing**

The information flow sequences for unsuccessful CFNRc operation are shown in figures 23 and 24.

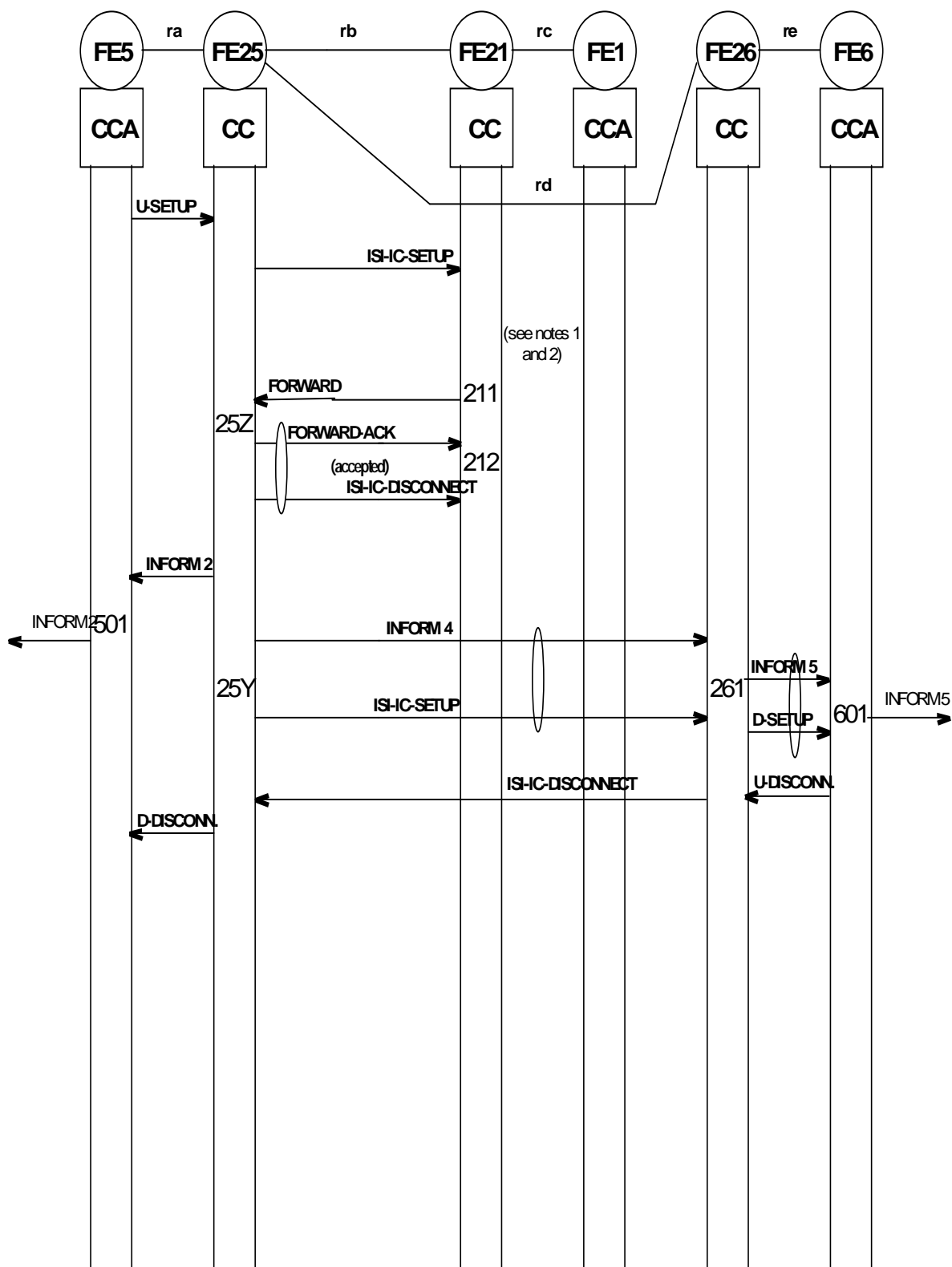

NOTE 1: User B is assumed to be not reachable at the invocation of SS-CF.

NOTE 2: Normal disconnection may also take place as a result of timer expiry or calling user aborting the call.

**Figure 23: Information flow sequences for unsuccessful CFNRc operation:  
CFNRc not completed, original call disconnected; case of re-routing**

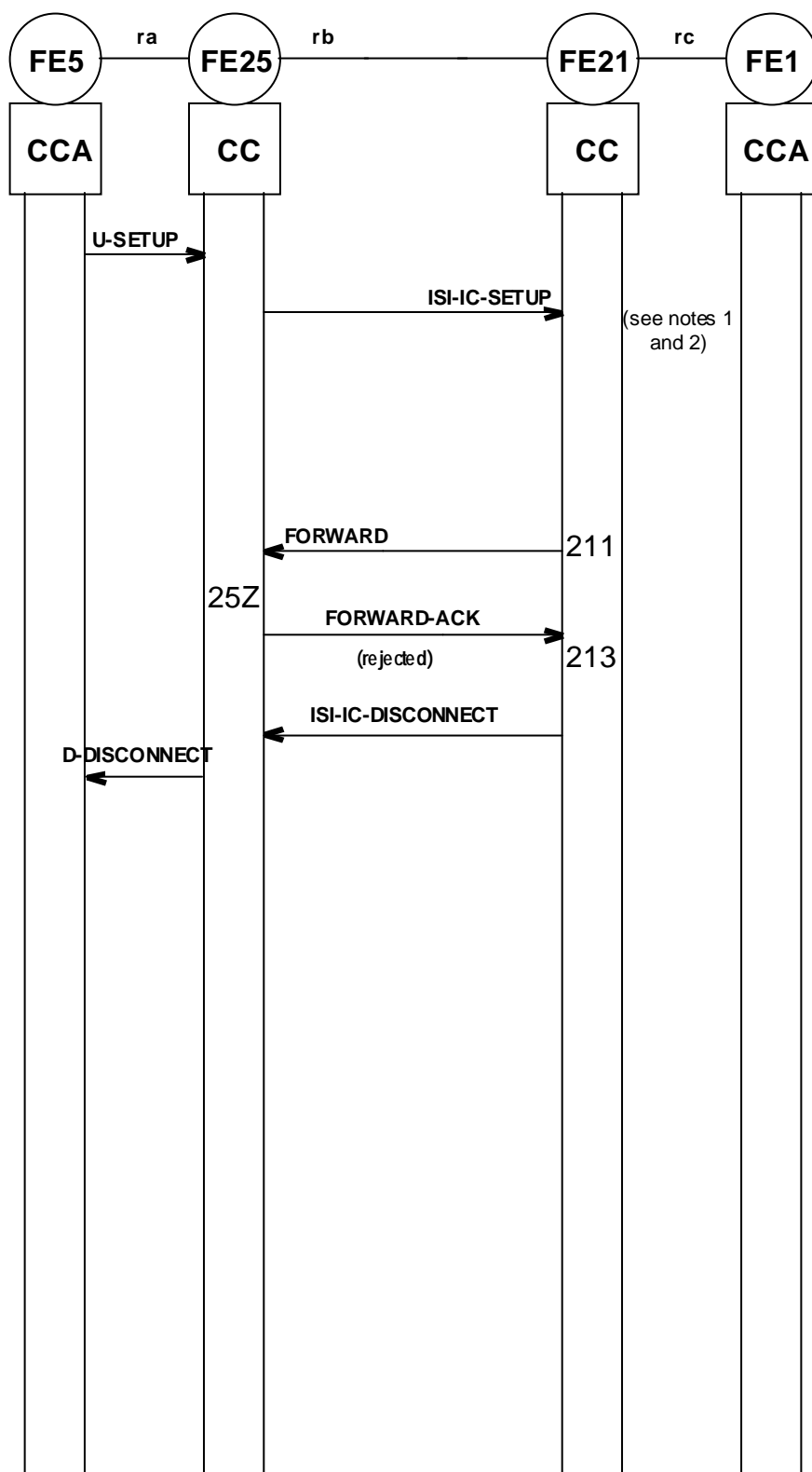

NOTE 1: User B is assumed to be not reachable at the invocation of SS-CF.

NOTE 2: Normal disconnection may also take place as a result of timer expiry or calling user aborting the call.

**Figure 24: Information flow sequences for unsuccessful CFNRc operation:  
CFNRc rejected, original call cleared; case of re-routeing**

4.1.2.2.1.4 Information flow sequence for double forwarding, individual call, case of re-routing

In order to show the case of a double forwarding in the case of re-routing where the first forwarded-to user is busy, figure 25 shows the corresponding information flow information flow.

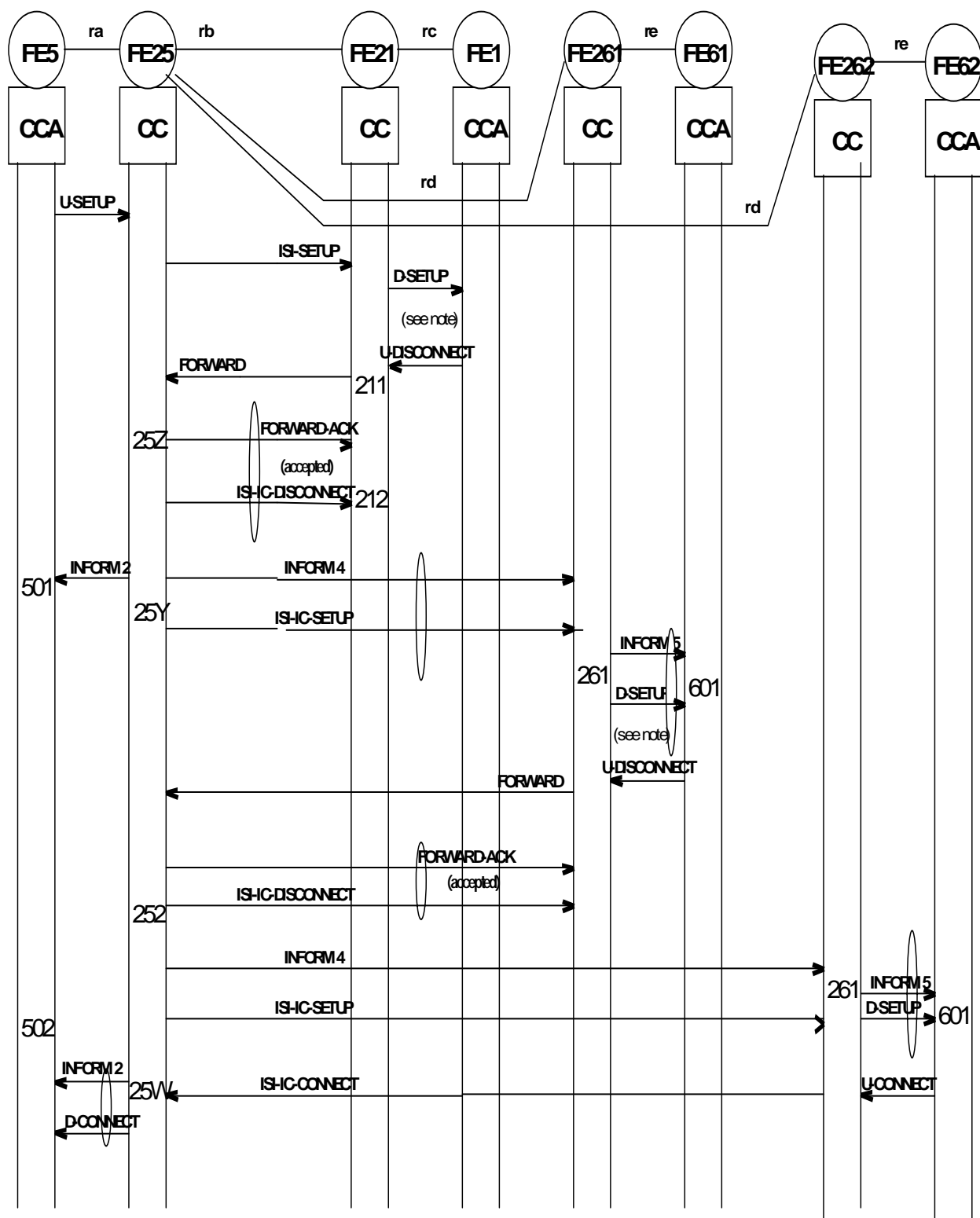

NOTE: Due to lack of drawing space, on this figure some primitives have not been shown.

Figure 25: Information flow sequence for double call forwarding CFB operation: User B1 busy; case of re-routing



## 4.1.2.2.1.5 Normal operation of FC

Figure 26 shows the information flow sequence for normal operation of FC.

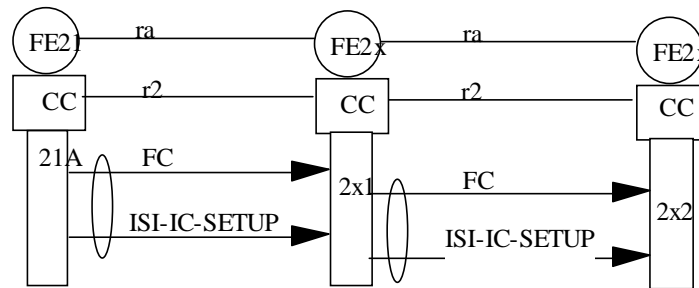

**Figure 26: Information flow sequence; normal operation of FC**

## 4.1.2.2.1.6 Forwarding counter limit exceeded

Figure 27 shows the information flow sequence for the case that the allowed limit of the forwarding counter is exceeded.

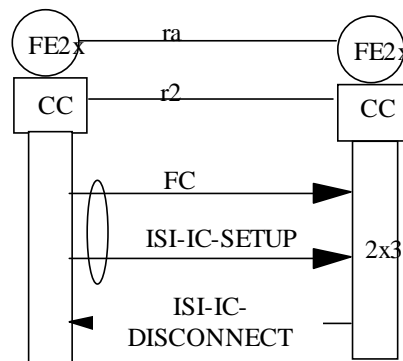

**Figure 27: Information flow sequence; forwarding counter limit exceeded**

4.1.2.2.1.7 Information flow sequences for SS-CF activation/deactivation

The information flow sequence for activation/deactivation of SS-CF is shown in figure 28.

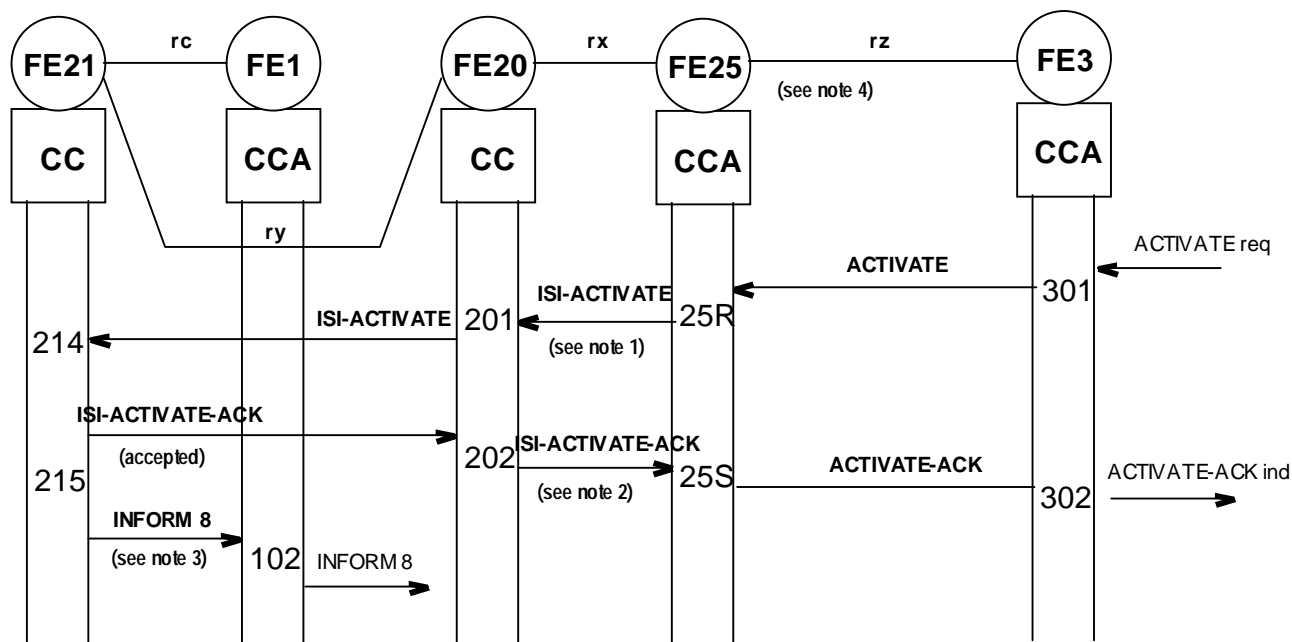

- NOTE 1: In the case where the visited swMI of served user is different from served user home SwMI, any change in profile in the visited SwMI will have to be authorized by the home SwMI. This flows does not exist for the deactivate process.
- NOTE 2: This information flow corresponds to the authorization of the profile change within the visited SwMI. This flows does not exist in the deactivate process.
- NOTE 3: In the case of deactivate flow, replace "ACTIVATE" by "DEACTIVATE" and INFORM 8 by INFORM 9 both for the information flow and for the primitive.
- NOTE 4: FE25 is any FE different from home SwMI FE. When FE3 is collocated with FE1, then the FE21 and FE25 also collocate.

Figure 28: Information flow sequence for activation/deactivation

4.1.2.2.1.8 Information flow sequence for enabling/disabling of SS-CF authorized user activation/deactivation

The information flow sequences for enabling/disabling of authorized user SS-CF activation/deactivation by the served user is shown in figure 29.

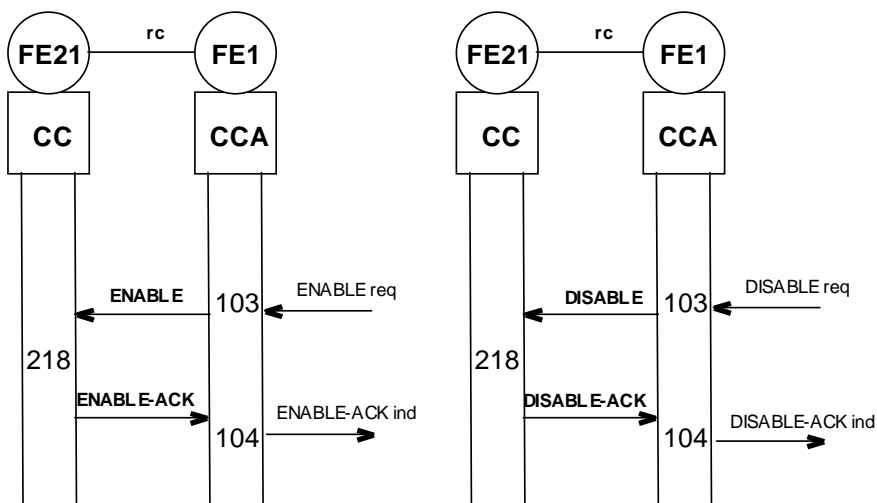

Figure 29: Information flow sequence for enabling/disabling of authorized user activation/deactivation

## 4.1.2.2.1.9 Information flow sequence for SS-CF interrogation

The information flow sequences for interrogation of SS-CF is shown in figure 30.

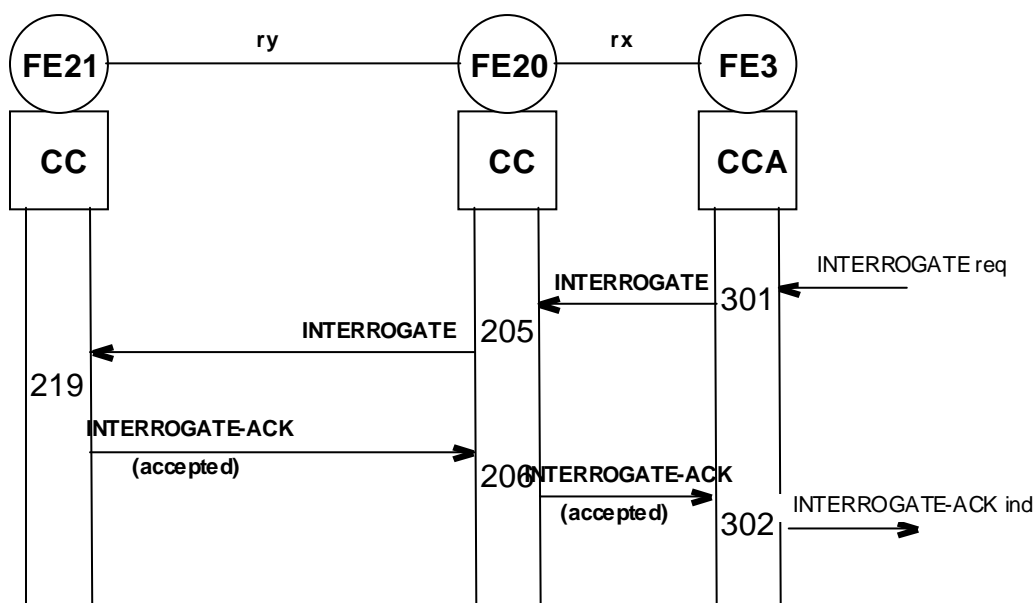

Figure 30: Information flow sequences for interrogation

## 4.1.2.3.2 Case of group call

In the case of group calls, only SS-CFU and SS-CFB are relevant; for group calls, forward switching does not apply; for group calls, only NDUB (Network Determined User (Group) Busy) applies; in the information flows concerning group calls that follow, the cases of group call forwarding to an ITSI and forwarding of an individual call to a GTSI are not shown.

4.1.2.3.2.1 Information flow sequences for CFU/CFB operation

The information flow sequence for successful CFU/CFB operation on group call is shown in figure 31. The case of SS-CFB corresponds to NDUB.

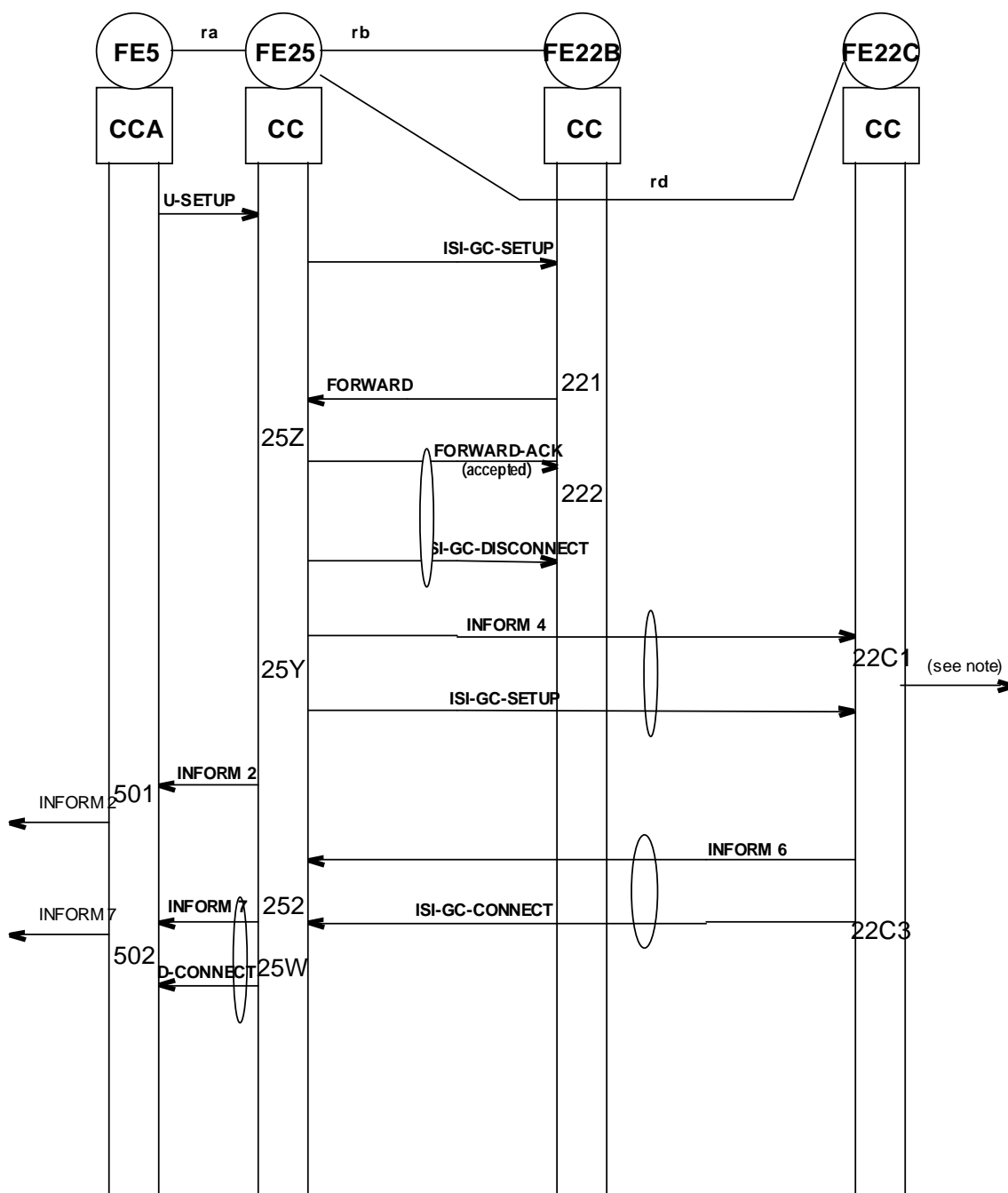

NOTE: The destination of the INFORM 5 information flow in the case of group call is implementation dependent; it could be dropped, presented to all members of the group or only presented to the group owner.

**Figure 31: Information flow sequence for successful CFU/CFB operation; case of group call; re-routeing**

The information flow sequences for unsuccessful CFU/CFB operation in the case of a group call are shown in figures 32 and 33.

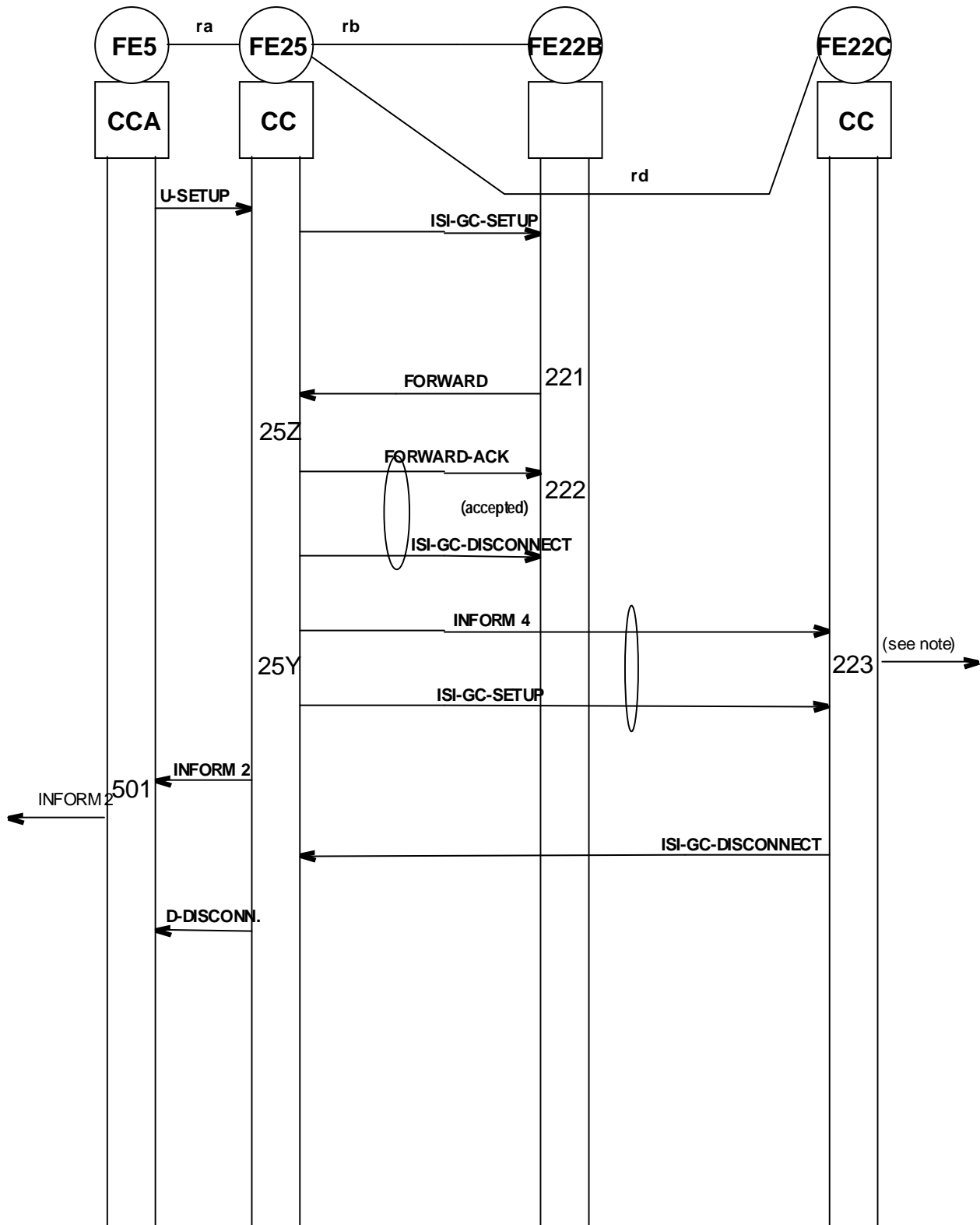

NOTE: The destination of the INFORM 5 information flow in the case of group call is implementation dependent; it could be dropped, presented to all members of the group or only presented to the group owner.

**Figure 32: Information flow sequence for unsuccessful CFU/CFB operation: case of group call; failure of forwarded call**

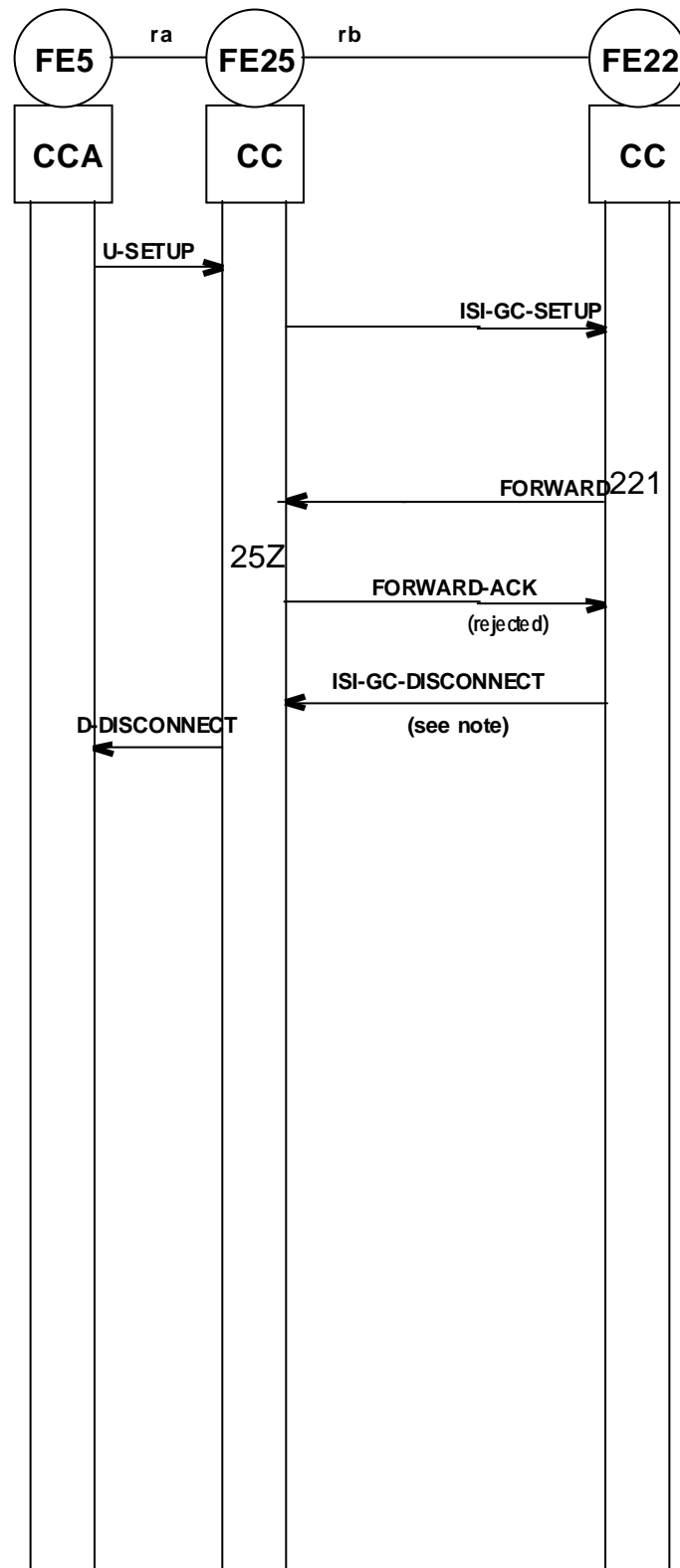

NOTE: With a disconnect cause "SS-specific disconnection".

**Figure 33: Information flow sequences for unsuccessful CFU/CFB operation: case of group call; rejection of call forwarding; case of re-routing only**

#### 4.1.2.3.2.2 Information flow sequences for SS-CF activation/deactivation

The information flow sequences for activation of SS-CF are the same as in the case of individual call, re-routing; clause 4.1.2.2.1.5 shall apply.

#### 4.1.2.3.2.3 Information flow sequence for enabling/disabling of authorized user SS-CF activation/deactivation

The information flow sequences for enabling/disabling of authorized user SS-CF activation/deactivation is the same as in the case of individual call, re-routeing, see clause 4.1.2.2.1.6.

#### 4.1.2.3.2.4 Information flow sequence for SS-CF interrogation

The information flow sequences for interrogation of SS-CF are the same as in the case of individual call, re-routeing see clause 4.1.2.2.1.7.

### 4.1.3 Functional entity actions

The following FEAs in clauses 4.1.3.1 to 4.1.3.11 shall occur at the points indicated in the figures of clause 4.1.2.2.

#### 4.1.3.1 Actions of FE1

102 Deliver notifications on activation and deactivation to the user as received from FE21.

103 Send enable/disable requests to FE21 as received from the user.

104 Deliver enable/disable responses to the user as received from FE21.

NOTE: Action numbers 105 and 106 are skipped (correspond in ECMA-173 [1] to CD actions).

#### 4.1.3.2 Actions of FE3

301 Send activation/deactivation/interrogation requests to FE20 as received from the user.

302 Deliver activation/deactivation/interrogation responses to the user as received from FE20.

#### 4.1.3.3 Actions of FE5

501 Deliver call forwarding notifications to the user as received from FE25 in INFORM 2.

502 Deliver number notifications to the user as received in INFORM 7 from FE25. This is an SS-CI [5] action and as such not a part of SS-CF actions.

#### 4.1.3.4 Actions of FE6

601 Deliver notifications to the forwarded-to user as received from FE26.

#### 4.1.3.5 Actions of FE20

201 Receive ACTIVATE/DEACTIVATE from FE3 and relay the ACTIVATE/DEACTIVATE to FE21.

202 Receive ACTIVATE ACK/DEACTIVATE ACK from FE21 and relay it to FE3.

NOTE: Actions 203 and 204 are duplicate of 201 202 in the case of DEACTIVATE.

205 Receive INTERROGATE from FE3 relay the INTERROGATE to FE21.

206 Receive INTERROGATE ACK from FE21 and relay it to FE3.

#### 4.1.3.6 Actions of FE21

- 211 Immediate in the case of CFU/CFNRc, on detection of busy in the case of CFB or after a specified time interval in case of CFNRy:
- recognize call forwarding activated and invoked from basic service;
  - increment the forwarding counter;
  - if the incremented forwarding counter has exceeded the upper limit, reject the forwarding request and for CFU/CFB and CFNRy/CFNRc release the call;
  - if the incremented forwarding counter is not above the upper limit, then send a FORWARD to FE25. This is actually a basic call action.
- 212 Receive the positive FORWARD ACK from FE25. This is actually a basic call action.
- 213 Receive the negative FORWARD ACK from FE25. For CFU/CFB/CFNRy: stimulate release of the call to the calling user.
- 214 Validate received ACTIVATE/DEACTIVATE.
- 215 Further validate received ACTIVATE/DEACTIVATE and respond to FE20 with ACTIVATE ACK/DEACTIVATE ACK. Inform FE1 of a successful activation/deactivation (INFORM 8 for ACTIVATE, INFORM9 FOR DEACTIVATE).
- NOTE: ACTIVATE and DEACTIVATE have been merged in a single information flow, thus the skip in action numbers 216 and 217 compared to ECMA-173 [1].
- 218 Validate received ENABLE/DISABLE and respond to FE1 with ENABLE ACK/DISABLE ACK.
- 219 Validate received INTERROGATE and respond to FE20 with INTERROGATE ACK.
- 21A Recognize the invocation of SS-CF invocation counter, set the SS-CF invocation counter to the initial value and send the SS-CF invocation counter value to FE2x. This action is actually a part of the basic call.

#### 4.1.3.7 Actions of FE22

- 221 Immediate in the case of CFU, on detection of busy in the case of CFB:
- recognize call forwarding activated and invoked from basic service;
  - increment the SS-CF invocation counter;
  - if the incremented SS-CF invocation counter has exceeded the upper limit, reject the forwarding request and for CFU/CFB release the call;
  - if the incremented SS-CF invocation counter is not above the upper limit, then send a FORWARD to FE25.
- 222 Receive the positive FORWARD ACK from FE25.
- 223 Determine if presentation of the number information received from FE25 in INFORM 4 is allowed and send INFORM 5 to the appropriate FE. Store the last forwarding number and original called number and associated presentation restriction indicators for further multiple call forwarding.
- 224 Send the presentation indicator of the diverted-to user's number on answer of the basic call to FE25 in INFORM 6. This action is an SS-CI [5] action and as such not a part of SS-CF actions.



#### 4.1.3.8 Actions at FE22C

- 22C1 Determine if presentation of the number information received from FE25 in INFORM 4 is allowed and send INFORM 5 to group members. Store the last forwarding number and original called number and associated presentation restriction indicators for further multiple call forwarding.
- 22C3 Send the presentation indicator of the diverted-to user's number on answer of the basic call to FE25 in INFORM 6. This action is an SS-CI [5] action and as such not a part of SS-CF actions.

#### 4.1.3.9 Actions of FE25

- 25Z Receive INFORM 6 from FE25, get the stored notification subscription options, determine if presentation of information is allowed and send the appropriate number information in INFORM 7 to FE5 if allowed. This is an SS-CI [5] action and as such not a part of the SS-CF actions.
- 25Z Receive FORWARD, check whether the request is allowed and valid and respond to FE21 with FORWARD ACK accordingly. This is actually a basic call action.
- 25Y Stimulate the basic call establishment to FE26 if the forwarding request is valid. Stimulate the release procedure at leg rb (original call) in case of CFU, CFB or CFNRy. Send INFORM 4 to FE26.
- 25W Relay the presentation indicator received in INFORM 6 from FE26 to FE5. This is an SS-CI [5] action and as such not a part of the SS-CI.
- 25V In case of CFNRy, optionally stimulate the release procedure at the forwarded-to leg (rd), when user B answers before alerting of user C.

NOTE: The present document assumes that once the CFNRy is invoked, then the originally called user cannot any more answer the call.

- 25U In case of SS-CF invocation by served user outside its home SwMI, send REPORT-INVOCATION to served user home SwMI FE21.
- 25T For CFNRy, stimulate release of the leg rd if the calling user releases the call.
- 25S In case of SS-CF activation (change of profile) by served user outside home SwMI, FE25 obtains authorization from home SwMI to activate (change profile) of SS-CF for served user.
- 25R In case of SS-CF activation (change of profile) by served user outside home SwMI, FE25 requests authorization from home SwMI to activate (change of profile) of SS-CF by served user.

#### 4.1.3.10 Actions of FE26

- 261 Determine if presentation of the number information received from FE25 in INFORM 4 is allowed and send INFORM 5 to FE6. Store the last forwarding number and original called number and associated presentation restriction indicators for further multiple call forwarding.
- 263 Send the presentation indicator of the diverted-to user's number on answer of the basic call to FE25 in INFORM 6. This action is an SS-CI [5] action and as such not a part of the SS-CF actions.

#### 4.1.3.11 Actions of FE2x

- 2x1 Acting as an intermediate FE2x, on receiving an SS-CF invocation counter value below the limit, increment the value and send the SS-CF invocation counter value to the next FE2x in the basic call signalling.
- 2x2 Acting as the final FE2x, on receiving the SS-CF innovation counter value, terminate the counting.
- 2x3 Acting as an intermediate FE2x, on receiving an SS-CF invocation counter value equal to or higher than the allowed limit, reject the call set-up request.

#### 4.1.4 Functional entity behaviour

The actions in clause 4.1.3 imply typical FE behaviour in terms of information flows sent and received. Related protocol is defined in EN 300 392-12-4 [4].

#### 4.1.5 Allocation of functional entities to physical equipment

The allocation of FEs to physical locations as shown in tables 21, 22 and 23 shall apply. In these tables, "TE" indicates a TE attached to a SwMI. Where a terminal involved is stimulus with respect to call forwarding, any FE shown as residing in the corresponding user's TE, shall reside instead in that user's SwMI.

**Table 21: Allocation for call forwarding operation by "re-routing"**

	User A FE5	User A FE25	FE25	User B FE21	User B FE1	User C FE26	User C FE6
<b>Scenario 1</b>	MS/LS	SwMI	Originating SwMI	SwMI	MS/LS	SwMI	MS/LS
<b>Scenario 2</b>	MS/LS	SwMI	Originating SwMI	SwMI	MS/LS	other network	other network
<b>Scenario 3</b>	other network	other network	Gateway SwMI	SwMI	MS/LS	SwMI	MS/LS
<b>Scenario 4</b>	other network	other network	Gateway SwMI	SwMI	MS/LS	other network	other network

**Table 22: Allocation for call forwarding activation/deactivation and interrogation**

	Served User B		De/activating User Interrogating User	
	FE21	FE1	FE20	FE3
<b>Scenario 5</b>	SwMI	MS/LS	User B Home SwMI	MS/LS
<b>Scenario 6</b>	SwMI	MS/LS	any SwMI	MS/LS
<b>Scenario 7</b>	other network	TE	other network	TE

Table 23 shows the allocation of functional entities to physical equipment.

**Table 23: Scenarios for the allocation of FEs for Forward Counter to physical equipment**

	FE21	FE2x (intermediate)	FE2x (final)
<b>Scenario 1</b>	Originating SwMI	Forwarding SwMI	Terminating SwMI
<b>Scenario 2</b>	Forwarding SwMI	Forwarding SwMI	Terminating SwMI

#### 4.1.6 Interworking considerations

In cases where FE25 or FE26 is in another network, information pertaining to relationship rb, rc or re shall be passed as appropriate to the other network by the gateway SwMI, except any restricted number information. In cases where FE21 is in another network, information pertaining to relationship rx shall be passed to the other network by the gateway SwMI, if the other network supports the equivalent information flow.

In cases where information is received from a FE located in another network by a gateway SwMI, the information required for SS-CFU, SS-CFB, SS-CFNry and SS-CFNrc shall be used by that SwMI.

**NOTE:** SS-CFNrc may not have any equivalent supplementary service in a fixed type of other network; in that case the gateway SwMI will have to map the SS-CFNrc related flows into flows that can be understood by the other network such as those of SS-CFNry.

SS-CF applies only to portions of a call that lie within the TETRA network. For calls to and from other networks the functional entities are allocated to physical equipment as shown in table 24.

**Table 24: Scenarios for the allocation of FEs to physical equipment in interworking situations**

	<b>FE21</b>	<b>FE2x (intermediate)</b>	<b>FE2x(final)</b>
<b>Scenario 3</b>	Originating SwMI	Forwarding SwMI	Outgoing gateway SwMI
<b>Scenario 4</b>	Forwarding SwMI	Forwarding SwMI	Outgoing gateway SwMI
<b>Scenario 5</b>	Incoming gateway SwMI	Forwarding SwMI	Terminating SwMI
<b>Scenario 6</b>	Incoming gateway SwMI	Forwarding SwMI	Outgoing gateway SwMI

## 4.2 Case of forward switching

This clause defines the stage 2 of the Call Forwarding supplementary services (CFU, CFB, CNFRy and CNRc) using the "forward switching" network routing algorithm. The term CF used here indicates that unless otherwise noted, the specification applies to all four supplementary services.

NOTE: The text concerning SS-CF invocation counter is not repeated here.

### 4.2.1 Functional model

#### 4.2.1.1 Functional model description

##### 4.2.1.1.1 SS-CF management

Clause 4.1.1.1.1 shall apply.

##### 4.2.1.1.2 Individual Calls

The functional model shall comprise the following functional entities (FEs):

- FE5: Calling user's service agent;
- FE25: Calling user's service control entity;
- FE21: Call diversion detection and control entity; call diversion execution entity;
- FE1: Served user's service agent;
- FE26: Diverted-to user's service control entity;
- FE6: Diverted-to user's service agent;
- FE20: User's activation, deactivation and interrogation control entity;
- FE3: User's activation, deactivation and interrogation agent.

The following functional relationships shall exist between these FEs:

- ra: between FE5 and FE25;
- rb: between FE25 and FE21;
- rd: between FE21 and FE1;
- re: between FE21 and FE26;
- rf: between FE26 and FE6;

- ry: between FE21 and FE20;
- rx: between FE20 and FE3.

Different types of call diversion (e.g. CFU, CFB, CFNRy and CFNRc) may be concatenated during multiple call diversion as well as different network routing algorithms (call diversion by "forward switching" and call diversion by "re-routeing").

#### 4.2.1.1.2.1 Single stage of call forwarding

Figure 34 shows the FEs and relationships for a single stage of call forwarding.

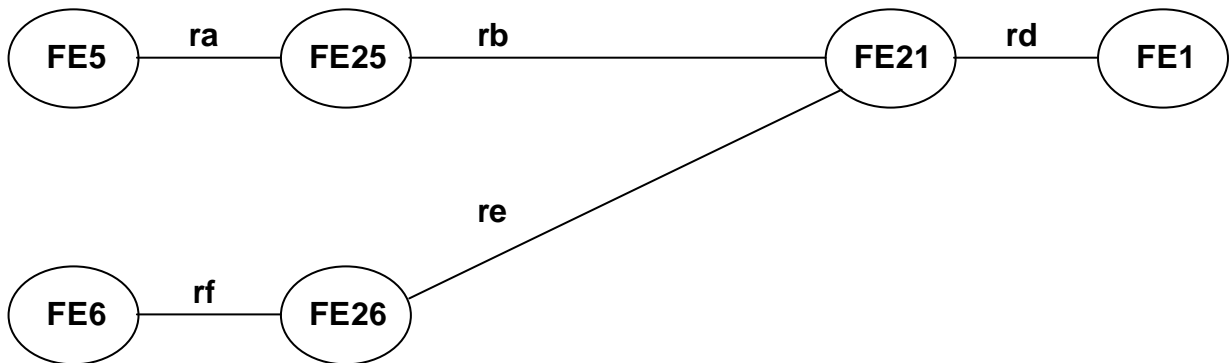

**Figure 34: Functional entity model for individual call, single stage of Call Forwarding and forward switching**

#### 4.2.1.1.2.2 Double stage of call forwarding

Figure 35 shows the FEs and relationships for two stages of call forwarding and individual call.

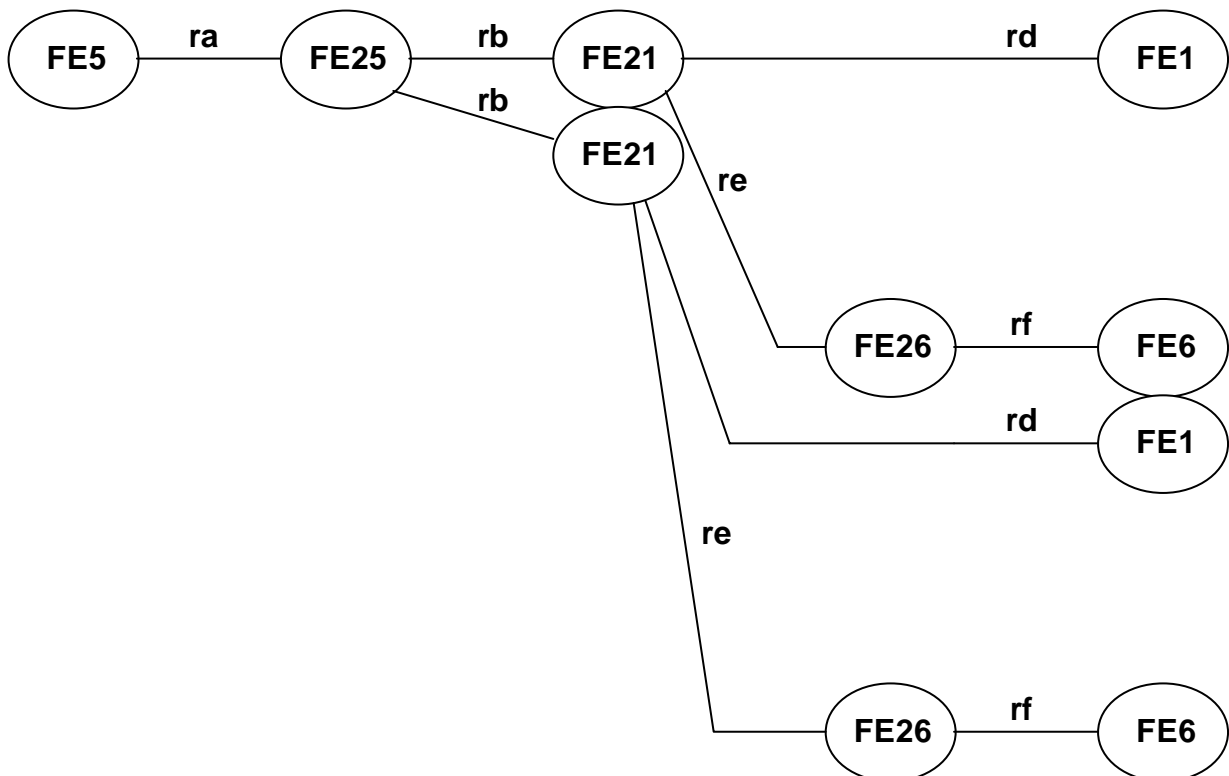

**Figure 35: Functional entity model for individual call and two stages of Call Forwarding**

## 4.2.1.2 Description of the functional entities

### 4.2.1.2.1 Calling user's service agent, FE5

This FE delivers the call forwarding notifications to the calling user.

### 4.2.1.2.2 Calling user's service control entity, FE25

This FE provides the appropriate call forwarding notifications to FE5 according to the information received from FE21 and FE26.

### 4.2.1.2.3 Served user service control entity; call forwarding detection, FE21

This FE detects a call forwarding request and supervises this request. FE21 provides a notification to FE1 and provides internal call forwarding information. FE 21 also receives activation, deactivation and interrogation requests from FE20 and provides responses to FE20. FE21 is responsible for modifying data related to activation, deactivation and authorized user activation enabling and disabling.

This FE executes call forwarding by initiating a new call establishment, and requesting release of the leg to the original called user. FE21 also relays call forwarding information to FE25 and FE26.

### 4.2.1.2.4 Served user service agent, FE1

This FE delivers call forwarding notifications to the served user.

### 4.2.1.2.5 Forwarded-to user service control entity, FE26

This FE provides appropriate call forwarding notifications to FE6 and provides also number presentation restriction information to FE25 via FE21.

### 4.2.1.2.6 Forwarded-to user service agent, FE6

This FE delivers call forwarding notification to the forwarded-to user.

### 4.2.1.2.7 Served user activation, deactivation and interrogation control, FE20

This FE relays activation, deactivation and interrogation requests and responses between FE3 and FE21.

### 4.2.1.2.8 Authorized user activation, deactivation and interrogation agent, FE3

This FE provides activation, deactivation and interrogation requests to FE20 and delivers corresponding responses to the requesting user.

## 4.2.1.3 Relationship of functional model to basic call functional model

Functional entity FE5 shall be collocated with user A's CCA.

NOTE 1: FE5 is optional and can be superseded by the basic call notification function.

Functional entity FE25 shall be collocated with user A's current SwMI CC or with any Incoming Gateway CC.

Functional entity FE21 shall be collocated with user B's home SwMI CC (users B1 ... Bn in case of multiple call forwarding) in the case of call forwarding by forward switching.

Functional entity FE1 shall be collocated with user B's CCA.

NOTE 2: FE1 has also management functions in which case it is within the served user's SS entity.

Functional entity FE26 shall be collocated with user C's current SwMI CC, and also with the CCs for users B2 ... Bn in case of multiple call forwarding.

Functional entity FE6 shall be collocated with user C's CCA.

Functional entity FE20 shall be within either the served user's SS or any authorized user's SS and is not linked to a basic call.

Functional entity FE3 shall be within either the served user's SS or any authorized user's SS and is not linked to a basic call.

An example of the relationship with a basic service is shown in figure 36. This example is used as the basis for the information flow sequence diagrams in clause 4.2.2.2.

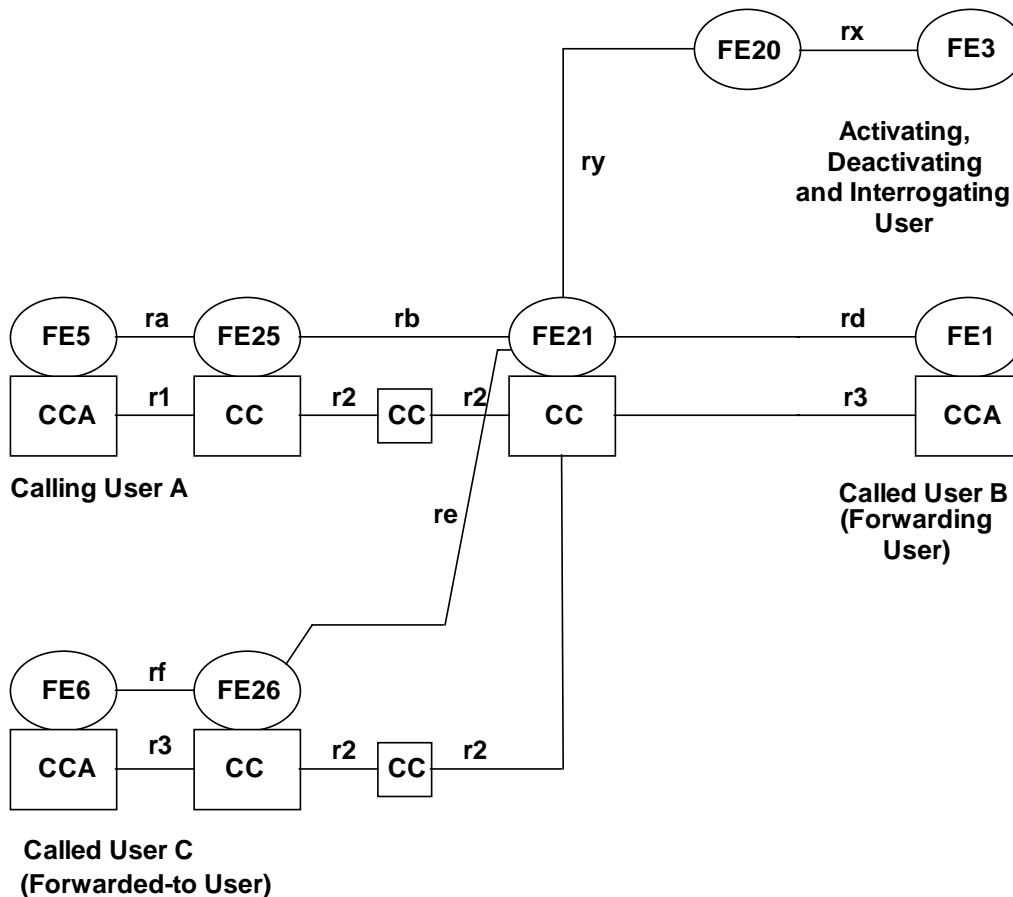

Figure 36: Functional entity model relationship, individual call, forward switching

#### 4.2.1.4 Service primitives

Clause 4.1.14 shall apply.

### 4.2.2 Information flows

#### 4.2.2.1 Definition of information flows

Information flows defined in clause 4.1.2 shall apply.

NOTE: The missing numbers in the INFORM sequence are to respect the ECMA numbering; those INFORMx information flows that appeared in ECMA and do not appear in the present document are skipped.

#### 4.2.2.2 Examples of information flow sequences

NOTE 1: Those information flows correspond to the case of forward switching; the functional entity FE23 (routing entity) of ECMA functional model is created within FE21 as soon as FORWARD ACK is received by FE21.

NOTE 2: In the information flow in clauses 4.2.2.1 to 4.2.2.4 INFORM 1 information flow is replaced by INFORM 2 information flow or is included into the corresponding basic call information flow and is shown only for historic reasons.

NOTE 3: In the information flow in clauses 4.2.2.1 to 4.2.2.4 INFORM 6 and INFORM 7 information flows are SS-CI [5] information flows and are shown only for historic reasons.

4.2.2.2.1 Information flow sequences for CFU/CFB operation

The information flow sequence for successful CFU/CFB operation is shown in figure 37.

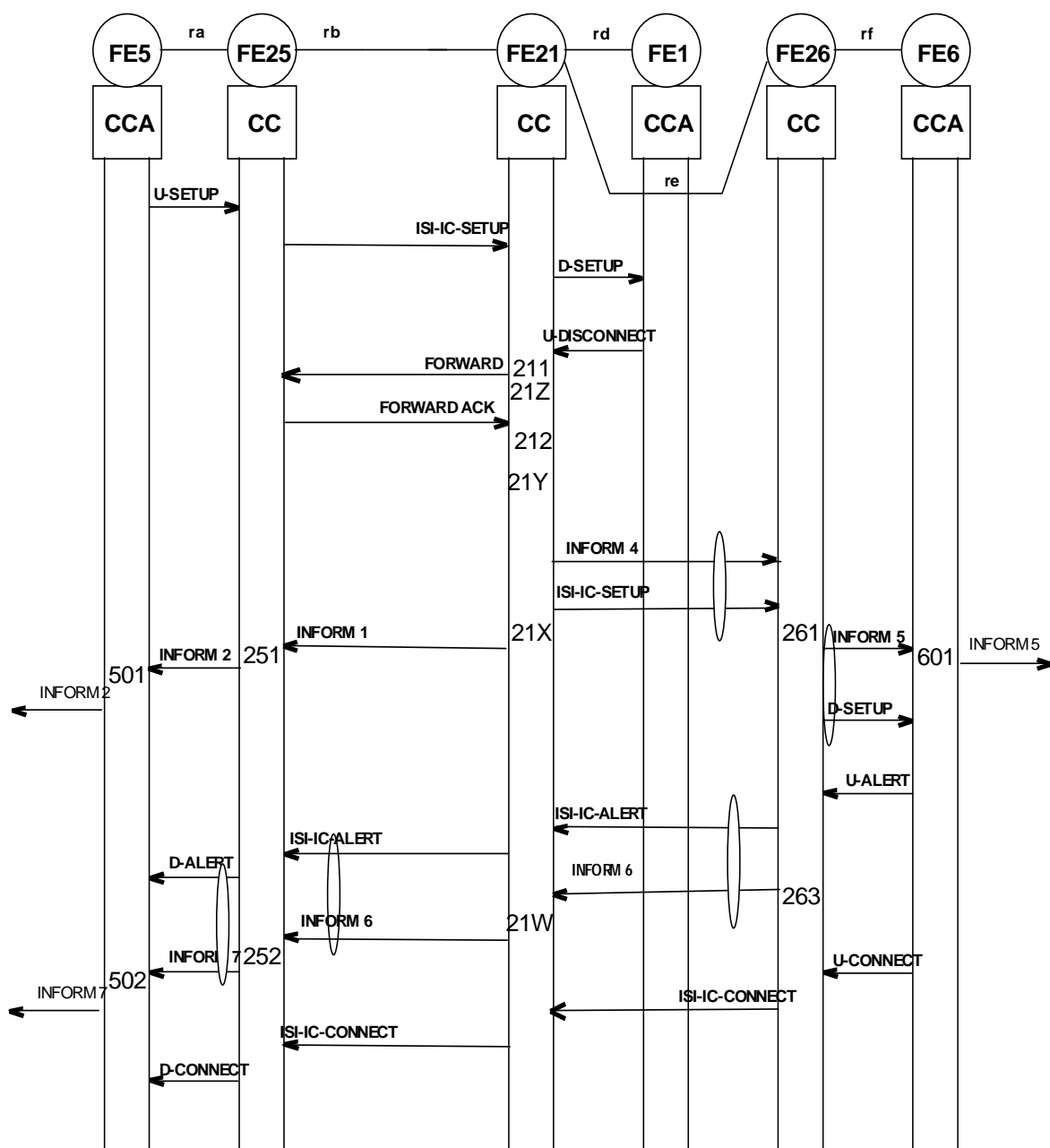
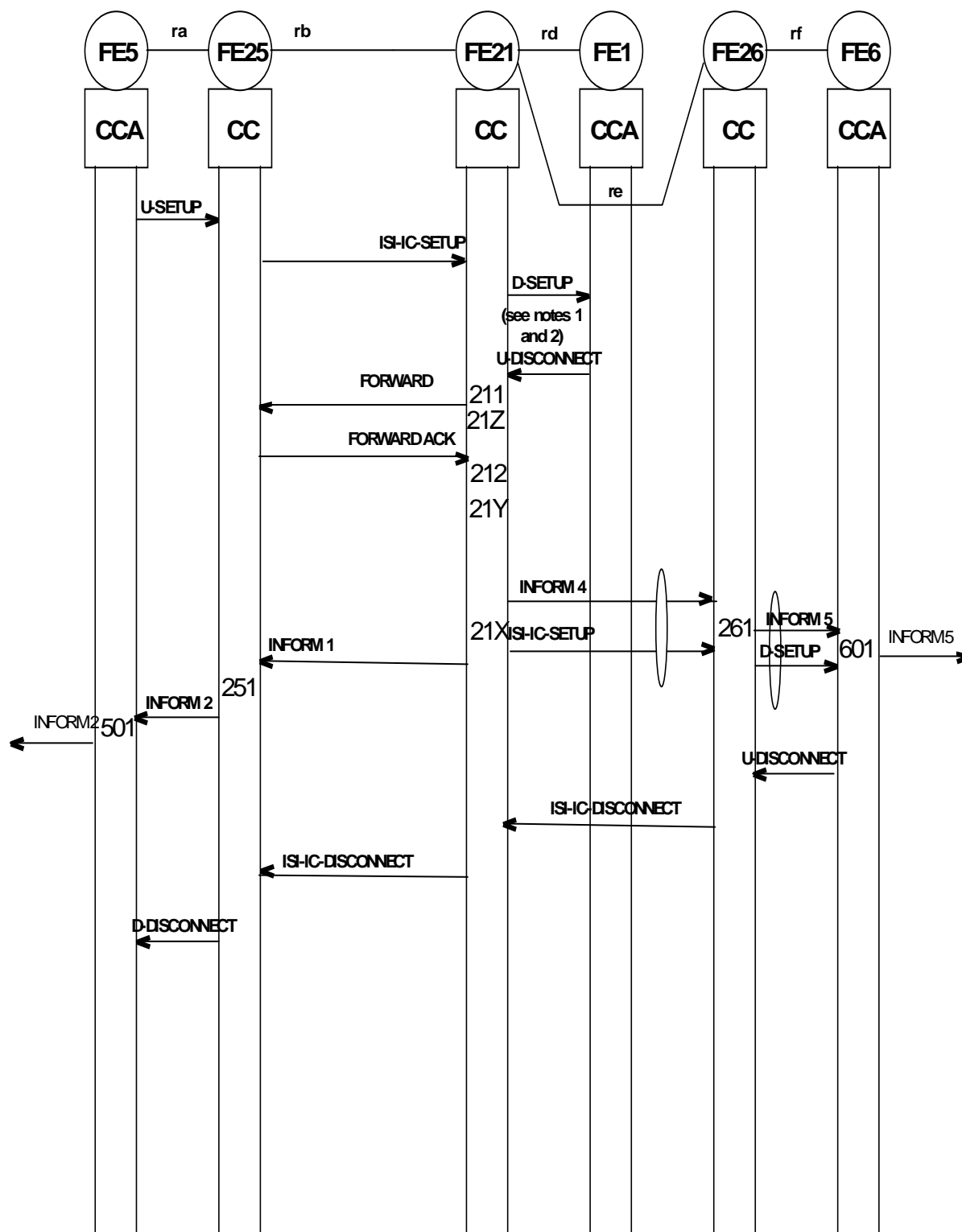

Figure 37: Information flow sequence for successful CFU/CFB operation; case of forward switching

The information flow sequences for unsuccessful CFU/CFB operation are shown in figures 38 and 39.



NOTE 1: This information flow is only applicable in case of CFB-UDUB.

NOTE 2: This information flow does not exist in the case of either CFU or CFB with UDUB.

**Figure 38: Information flow sequence for unsuccessful CFU/CFB operation: failure of forwarded call; case of forward switching**



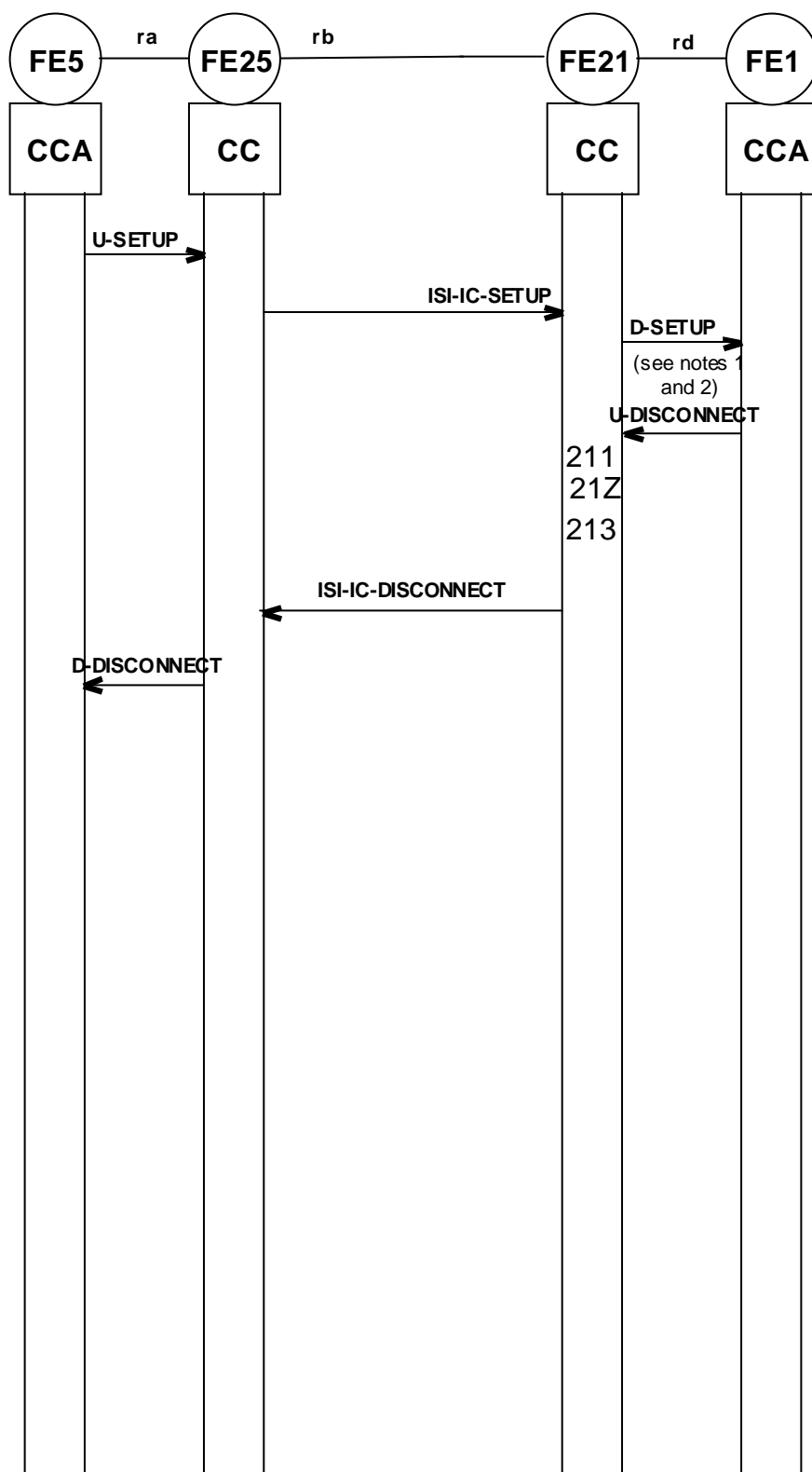

NOTE 1: This information flow is only applicable in case of CFB-UDUB.

NOTE 2: This information flow does not exist in the case of either CFU or CFB with UDUB.

**Figure 39: Information flow sequences for unsuccessful CFU/CFB operation:  
Rejection of Call Forwarding; case of forward switching**

## 4.2.2.2.2 Information flow sequences for CFNRy operation

The information flow sequence for successful CFNRy operation is shown in figure 40.

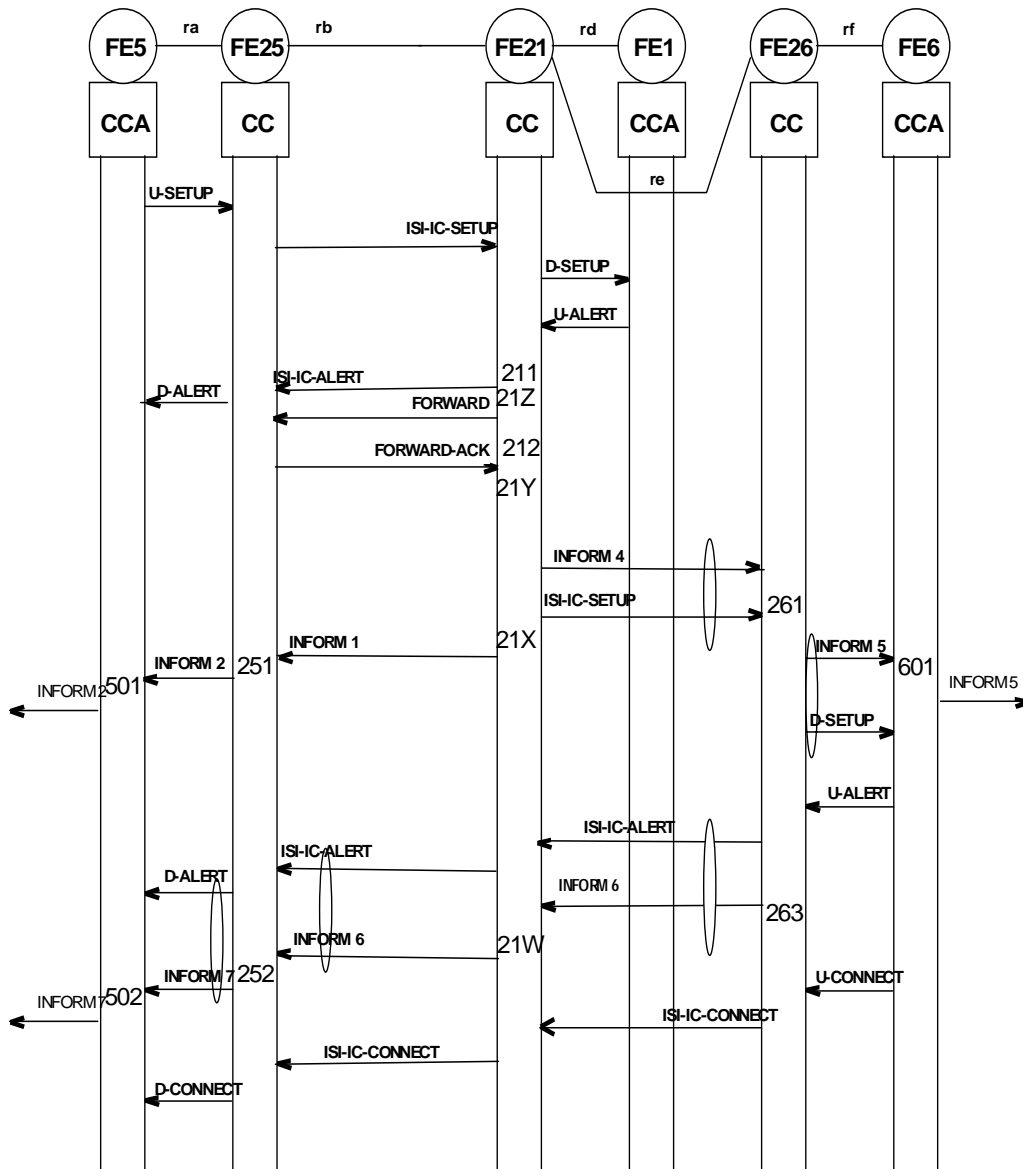

Figure 40: Information flow sequence for successful CFNRy operation; case of forward switching

The information flow sequence for clearing by user A during CFNRy operation is shown in figure 41.

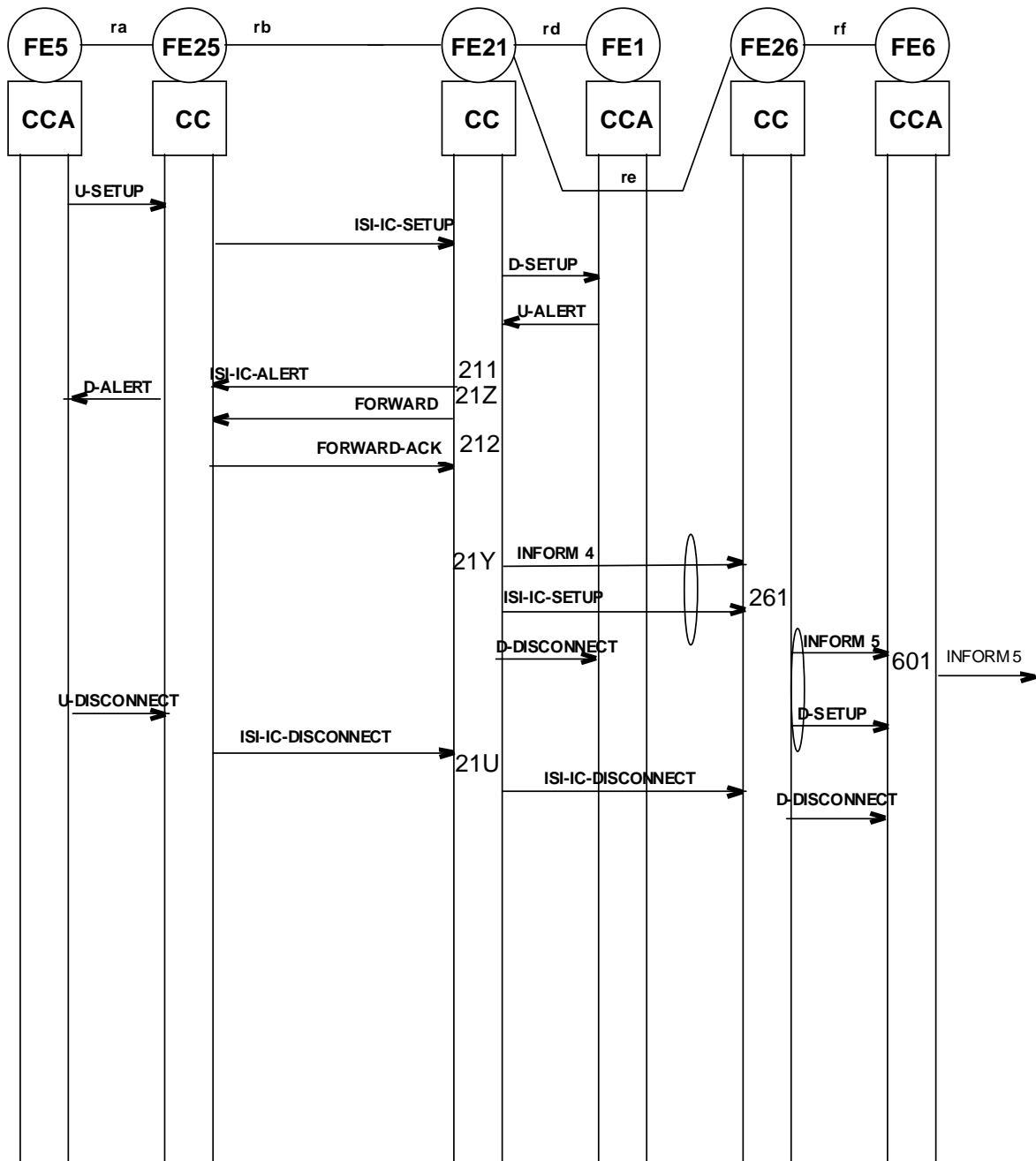

Figure 41: Information flow sequence for clearing by user A during CFNRy operation; case of forward switching

The information flow sequences for unsuccessful CFNRy operation are shown in figures 42 and 43.

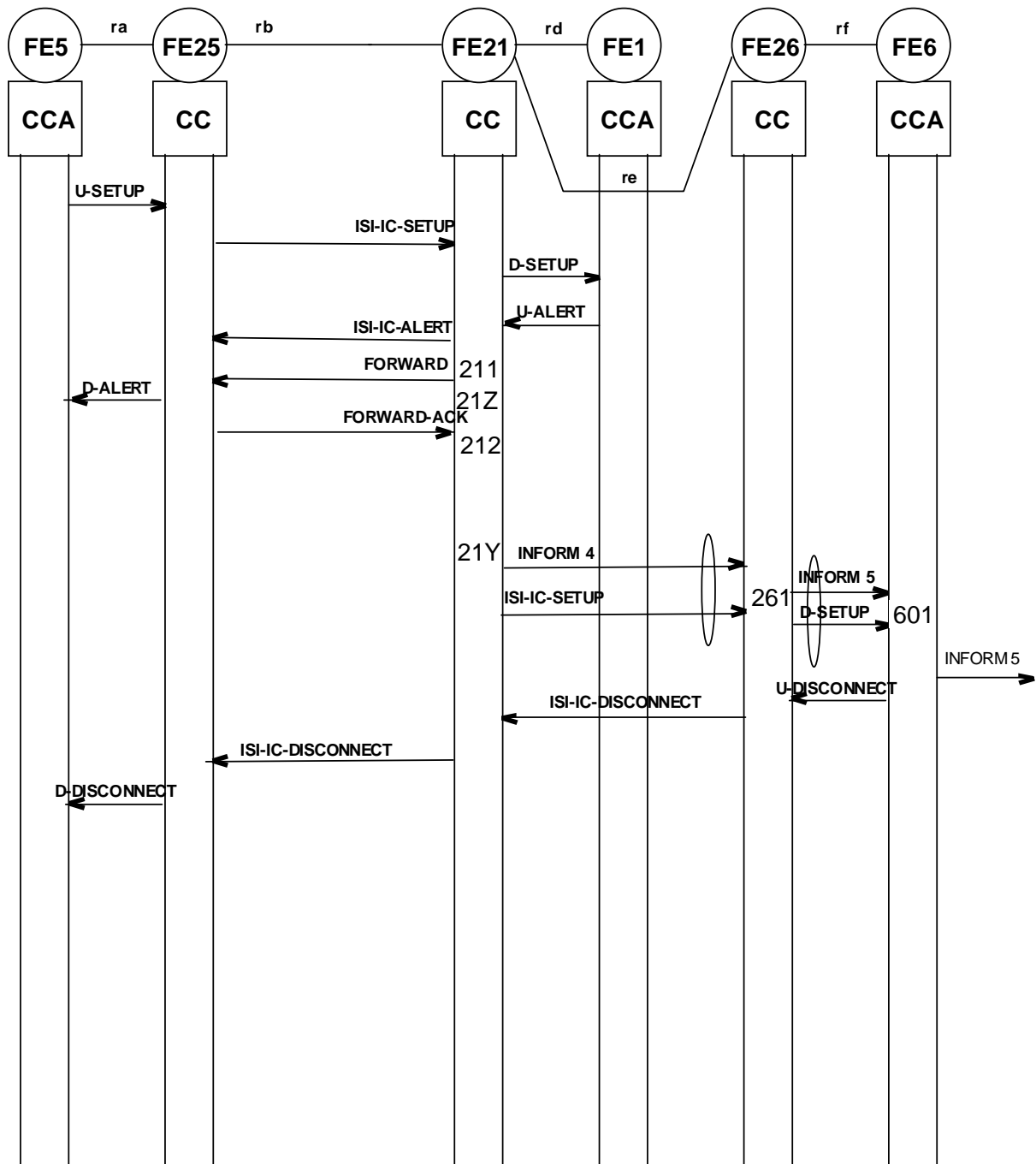

Figure 42: Information flow sequences for unsuccessful CFNRy operation: CFNRy not completed, original call cleared; case of forward switching

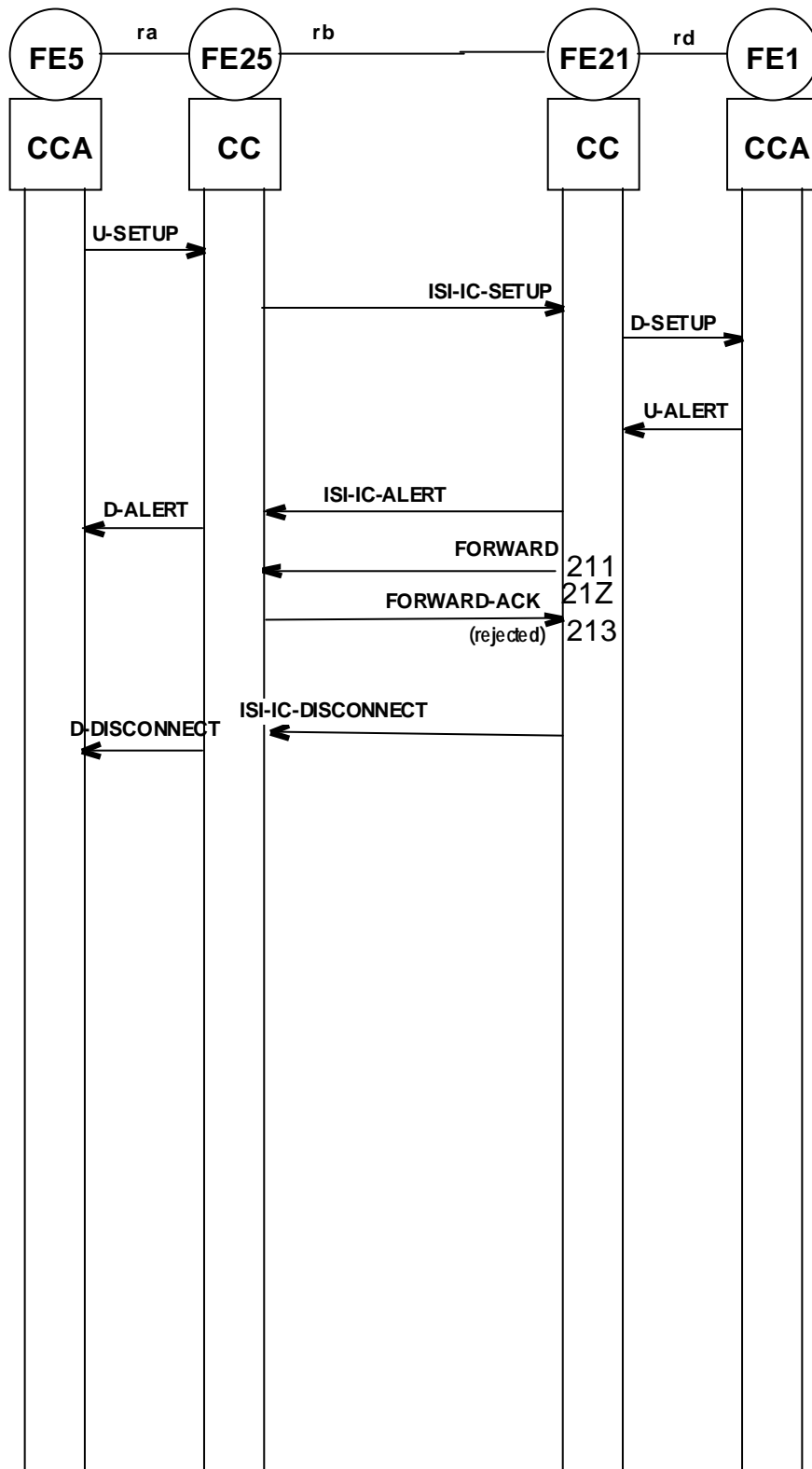
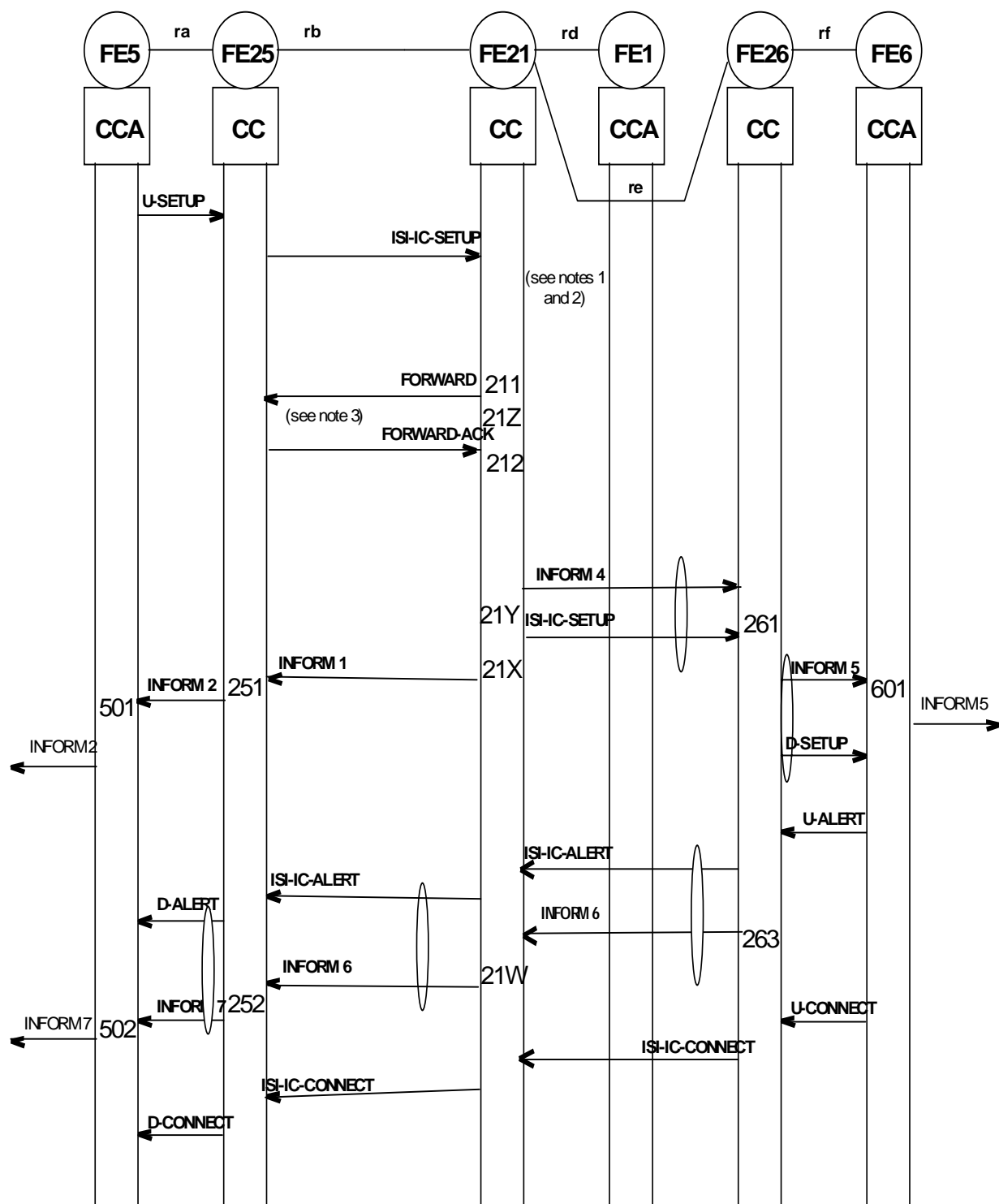

Figure 43: Information flow sequences for unsuccessful CFNRy operation: CFNRy rejected, original call cleared; case of forward switching

## 4.2.2.2.3 Information flow sequences for CFNRc operation

The information flow sequences for CFNRc are not basically different from those for CFNRy; however, those flows are shown for completeness. The information flow sequence for successful CFNRc operation is shown in figure 44.



NOTE 1: It is assumed that FE1 is not reachable at the invocation of the SS-CF.

NOTE 2: No INFORM information flow can be transferred.

NOTE 3: The call forwarding invocation inhibits the ISI-DISCONNECT with cause "Called party not reachable" which would normally be sent.

Figure 44: Information flow sequence for successful CFNRc operation; case of forward switching

The information flow sequence for clearing by user A during CFNRc operation is shown in figure 45.

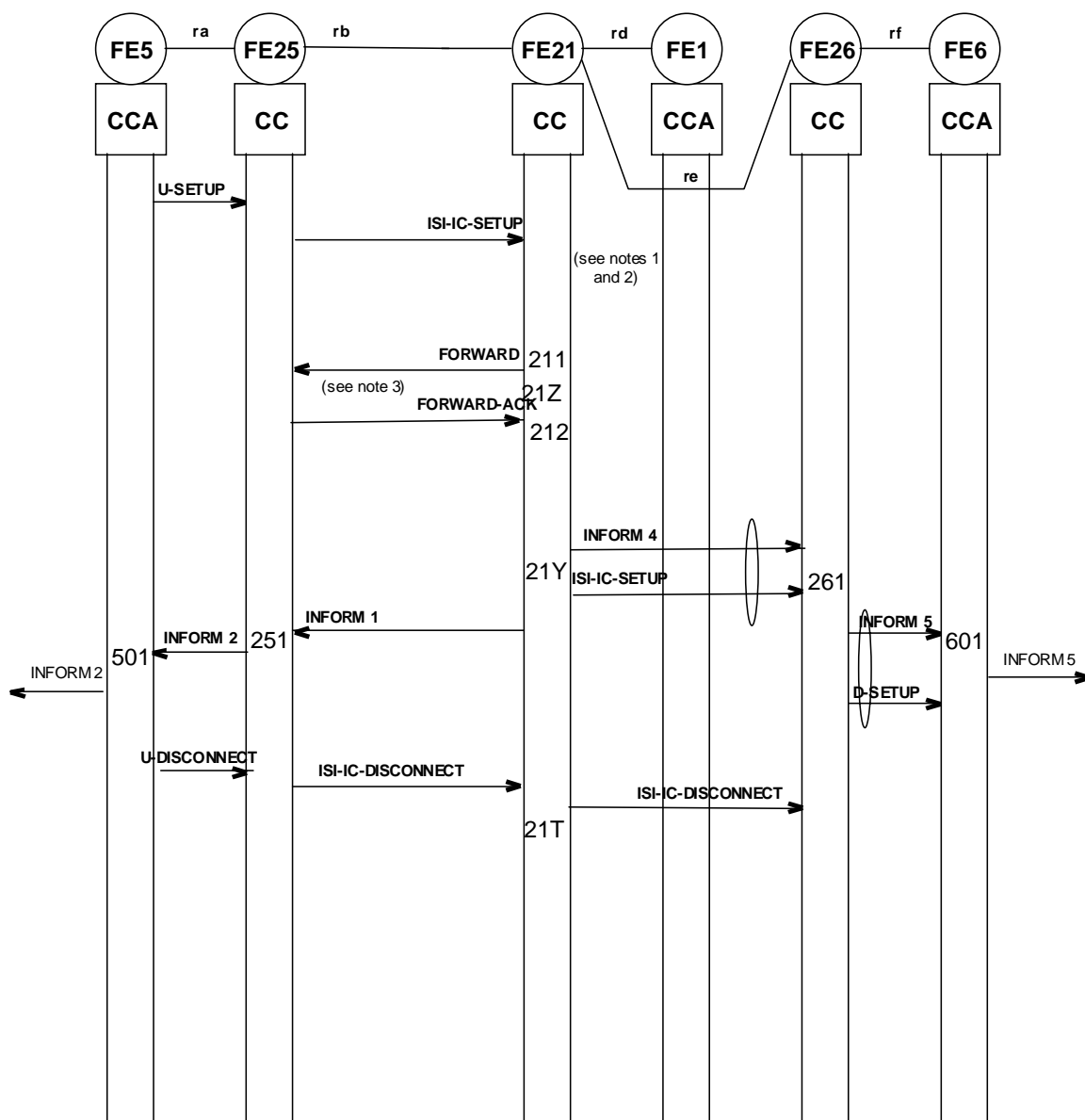

NOTE 1: It is assumed that FE1 is not reachable at the invocation of the SS-CF.

NOTE 2: No INFORM information flow can be transferred.

NOTE 3: The call forwarding invocation inhibits the ISI-DISCONNECT with cause "Called party not reachable" which would normally be sent.

**Figure 45: Information flow sequence for clearing by user A during CFNRc operation; case of forward switching**

The information flow sequences for unsuccessful CFNRc operation are shown in figures 46 and 47.

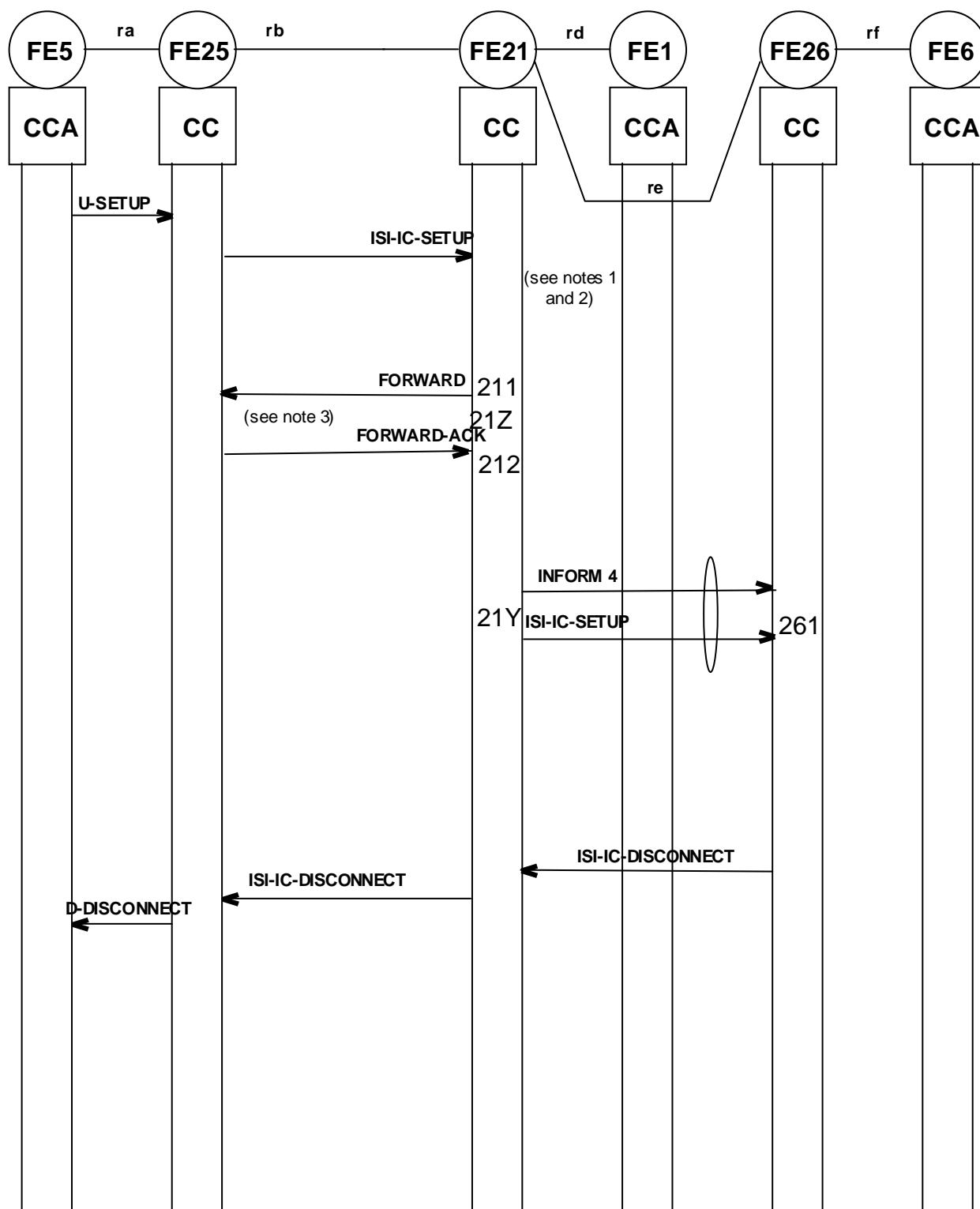

**Figure 46: Information flow sequences for unsuccessful CFNRc operation: CFNRc not completed, original call cleared; case of forward switching**



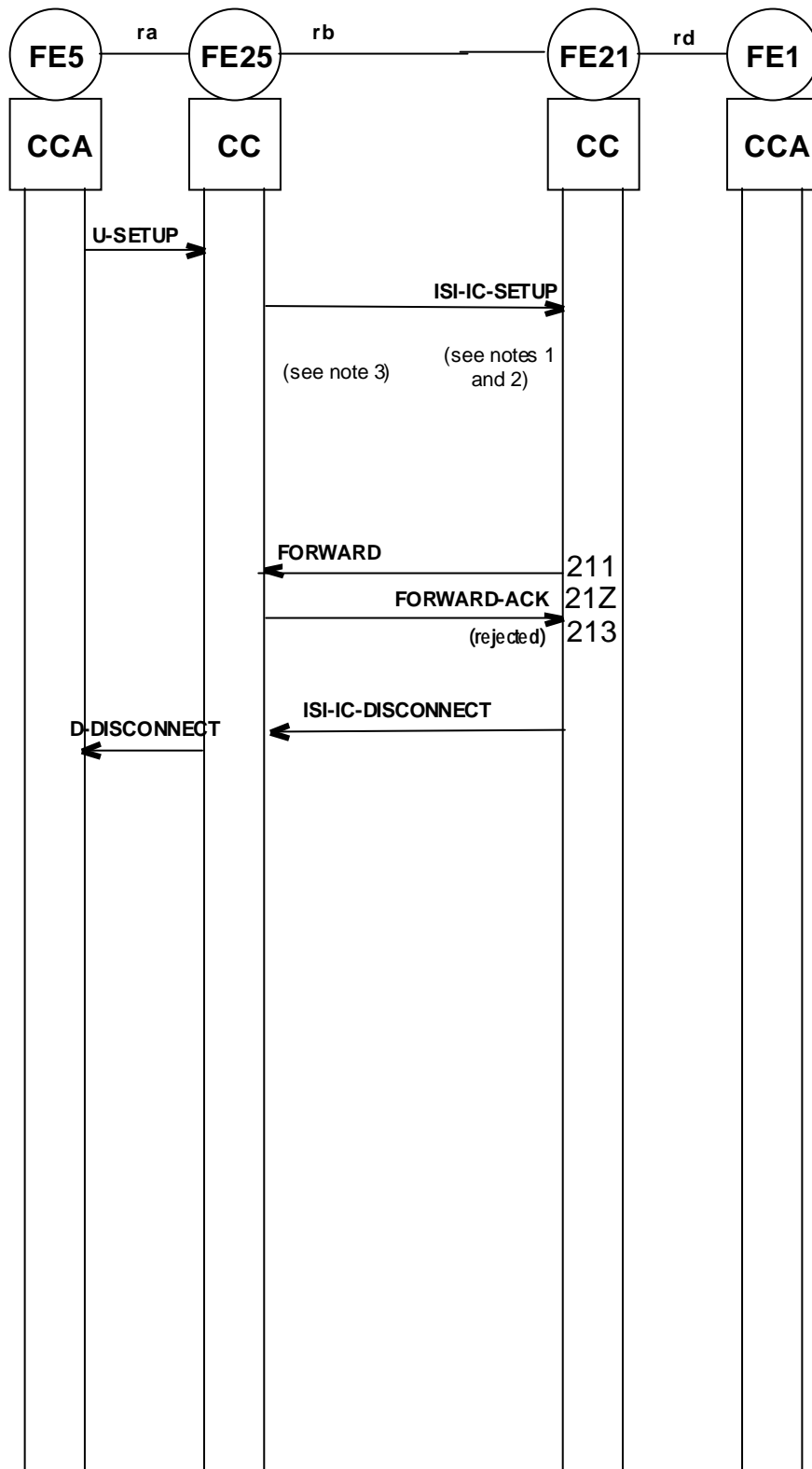

NOTE 1: It is assumed that FE1 is not reachable at the invocation of the SS-CF.

NOTE 2: No INFORM information flow can be transferred.

NOTE 3: The call forwarding invocation inhibits the ISI-DISCONNECT with cause "Called party not reachable" which would normally be sent.

**Figure 47: Information flow sequences for unsuccessful CFNRy operation:  
CFNRc rejected, original call cleared; case of forward switching**

#### 4.2.2.2.4 Information flow sequences for two stage forwarding, individual call, forward switching

As an illustration of how a double stage individual call forwarding would operate in the case of forward switching, the information flow sequence is given in figure 48.

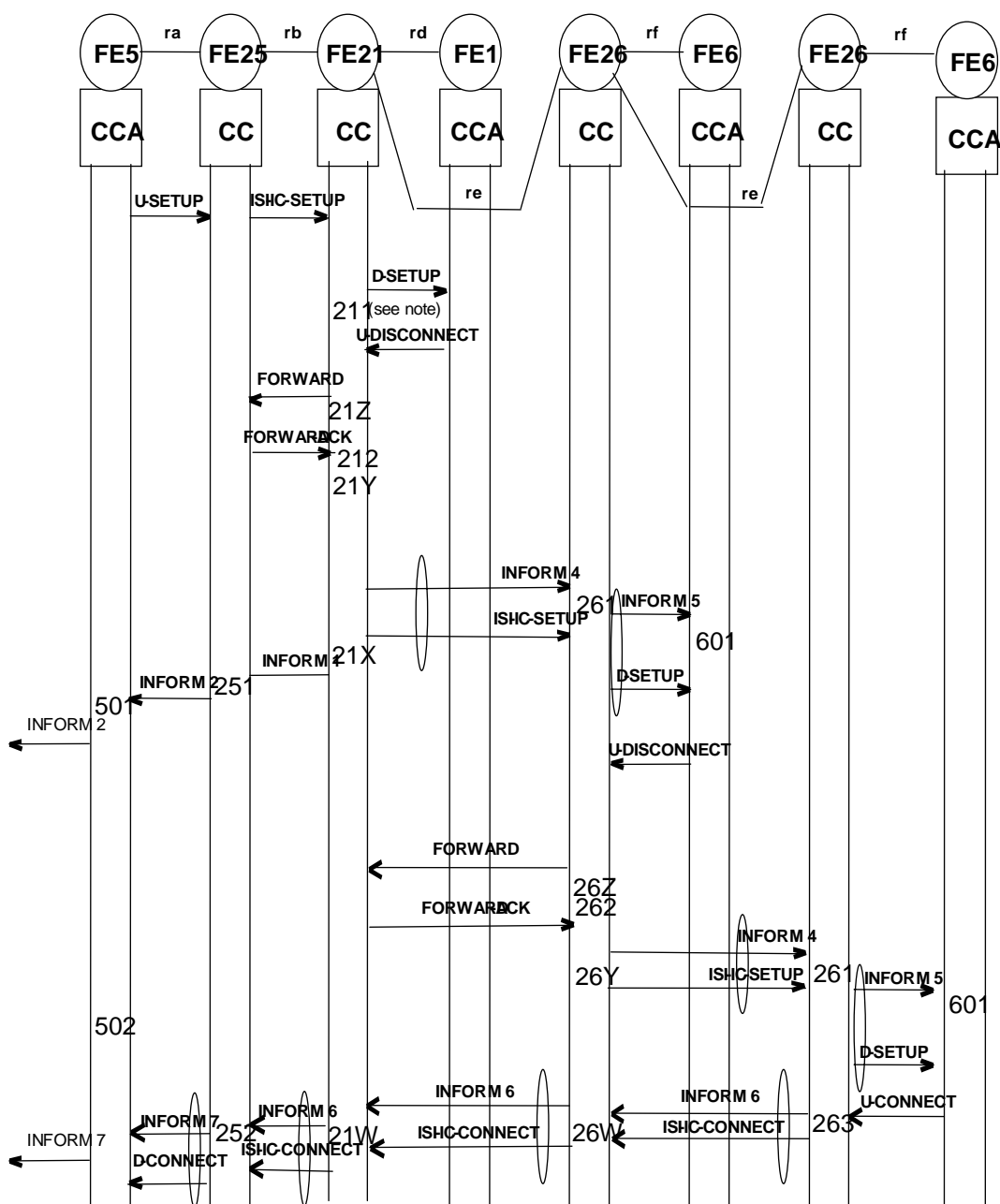

NOTE: This information flow is not applicable in case of CFU.

**Figure 48: Information flow sequences for successful CFU double stage operation; case of forward switching**

#### 4.2.2.2.5 Information flow sequences for SS-CF activation/deactivation

The information flow sequences for activation of SS-CF are the same as in the case of re-routing; clause 4.1.2.2.1.5 shall apply.

#### 4.2.2.2.6 Information flow sequence for enabling/disabling of SS-CF authorized user activation/deactivation

The information flow sequences for enabling/disabling of SS-CF activation/deactivation authorized user is the same as in the case of re-routing; clause 4.1.2.2.1.6 shall apply.

#### 4.2.2.2.7 Information flow sequence for SS-CF interrogation

The information flow sequences for interrogation of SS-CF are the same as in the case of re-routing; clause 4.1.2.2.1.7 shall apply.

### 4.2.3 Functional entity actions

The following FEAs in clauses 4.2.3.1 to 4.2.3.8 shall occur at the points indicated in the figures of clause 4.2.2.

#### 4.2.3.1 Actions of FE1

- 102 Deliver notifications on activation and deactivation to the user as received from FE21.
- 103 Send ENABLE/DISABLE to FE21 as received from the served user.
- 104 Deliver ENABLE-ACK/DISABLE-ACK to the served user as received from FE21.

#### 4.2.3.2 Actions of FE3

- 301 Send activation/deactivation/interrogation requests to FE20 as received from the user.
- 302 Deliver activation/deactivation/interrogation responses to the user as received from FE20.

#### 4.2.3.3 Actions of FE5

- 501 Deliver call forwarding notifications to the user as received from FE25 in INFORM 2.
- 502 Deliver number notification to the user as received in INFORM 7 from FE25. This action is an SS-CI [5] action and as such not a part of the SS-CF actions.

#### 4.2.3.4 Actions of FE6

- 601 Deliver notifications to the forwarded-to user as received from FE26.

#### 4.2.3.5 Actions of FE20

- 201 Receive ACTIVATE from FE3 and relay the ACTIVATE to FE21.
- 202 Receive ACTIVATE ACK from FE21 and relay it to FE3.
- 203 Receive DEACTIVATE from FE3 and relay the DEACTIVATE to FE21.
- 204 Receive DEACTIVATE ACK from FE21 and relay it to FE3.
- 205 Receive INTERROGATE from FE3 and relay the INTERROGATE to FE21.
- 206 Receive INTERROGATE ACK from FE21 and relay it to FE3.

#### 4.2.3.6 Actions of FE21

- 211 Immediate in the case of CFU, on detection of busy in the case of CFB, on detection of not reachable in case of CFNRc or after a specified time interval in case of CFNRy:
  - recognize call forwarding activated and invoked from basic service;
  - increment the SS-CF invocation counter.

- 21Z If the incremented SS-CF invocation counter value has exceeded the upper limit, reject the forwarding request and release the original call;
- if the incremented forwarding counter is not above the upper limit, then send a FORWARD to FE25. This is a basic call action.
- 212 Receive the positive FORWARD ACK from FE25.
- 213 Receive the negative FORWARD ACK from FE25. Stimulate release of the call to the calling user.
- 214 Validate received ACTIVATE.
- 215 Further validate received ACTIVATE and respond to FE20 with ACTIVATE ACK. Inform FE1 of a successful activation (INFORM 8).
- 216 Validate received ACTIVATE and respond to FE20 with ACTIVATE ACK. Inform F1 of a successful activation (INFORM 8).
- 217 Validate received DEACTIVATE and respond to FE20 with DEACTIVATE ACK. Inform FE1 of a successful deactivation (INFORM 9).
- 218 Validate received ENABLE/DISABLE and respond to FE1 with ENABLE-ACK/DISABLE-ACK.
- 219 Validate received INTERROGATE and respond to FE20 with INTERROGATE ACK.
- 21Y In the case where the FORWARD ACK received from FE25 is positive and indicates call forwarding by forward switching, stimulate the basic call establishment to FE26 if the forwarding request is valid. Send INFORM 4 to FE26.
- 21X In case of CFNRy/CFNRc and on UDUB of CFB, stimulate the release procedure at leg rc.
- NOTE: In TETRA an invocation of CF removes any possibility that the originally called user can answer the call any more.
- 21W Relay the presentation indicator received in INFORM 6 from FE26 to FE25. This is an SS-CI [5] action and as such not a part of the SS-CF actions.
- 21T For CFNRy/CFNRc, stimulate release of the legs rc and re if the calling user releases the call.

#### 4.2.3.7 Actions of FE25

- 251 Receive (multiple) INFORM 2(INFORM 1) and/or Notification indicator values from FE21 and pass those to FE5.
- 252 Receive INFORM 6 from FE21, get the stored notification subscription options, determine if presentation of information is allowed and send the appropriate number information in INFORM 7 to FE5 if allowed. The latter is an SS-CI [5] action and as such not a part of the SS-CF actions.

#### 4.2.3.8 Actions of FE26

- 261 Determine if presentation of the number information received from FE21 in INFORM 4 is allowed and send INFORM 5 to FE6. Store the last forwarding number and original called number and associated presentation restriction indicators for further multiple call forwarding.
- 263 Send the presentation indicator of the forwarded-to user's number of the forwarded-to user on CONNECT of the basic call to FE21 in INFORM 6. This action is an SS-CI [5] action and as such not a part of the SS-CF actions.

In the case of repeated invocation of forward switching:

- 26Z see 21Z above;
- 26Y see 21Y above;
- 26X see 21X above.

## 4.2.4 Functional entity behaviour

Clause 4.1.4 shall apply.

## 4.2.5 Allocation of functional entities to physical equipment

The allocation of FEs to physical locations as shown in table 25 shall apply. In this table, "TE" indicates a TE attached to a non-TETRA network.

**Table 25: Allocation for call diversion operation by "forward switching"**

	User A FE5	User A FE25	User B FE21	User B FE1	User C FE26	User C FE6
<b>Scenario 8</b>	MS/LS	SwMI	SwMI	MS/LS	SwMI	MS/LS
<b>Scenario 9</b>	TE	other network	other network	other network	other network	other network
<b>Scenario 10</b>	other network	other network	SwMI	MS/LS	other network	other network
<b>Scenario 11</b>	other network	other network	other network	other network	SwMI	MS/LS
<b>Scenario 12</b>	TE	other network	other network	other network	SwMI	MS/LS
<b>Scenario 13</b>	MS/LS	SwMI	SwMI	MS/LS	other network	other network
<b>Scenario 14</b>	other network	other network	SwMI	MS/LS	SwMI	MS/LS
<b>Scenario 15</b>	other network	other network	other network	TE	other network	other network
<b>Scenario 16</b>	other network	other network	other network	TE	SwMI	MS/LS
<b>Scenario 17</b>	TE	other network	other network	TE	other network	other network
<b>Scenario 18</b>	TE	other network	other network	TE	PINX	TE
<b>Scenario 19</b>	other network	other network	SwMI	MS/LS	other network	other network
<b>Scenario 20</b>	TE	other network	SwMI	MS/LS	other network	other network
<b>Scenario 21</b>	other network	other network	SwMI	MS/LS	SwMI	MS/LS
<b>Scenario 22</b>	TE	other network	SwMI	MS/LS	SwMI	MS/LS

## 4.2.6 Interworking considerations

Clause 4.1.6 shall apply.

---

## Annex A (informative): Bibliography

- ETSI EN 300 392-10-4: "Terrestrial Trunked Radio (TETRA); Voice plus Data (V+D); Part 10: Supplementary services stage 1; Sub-part 4: Call diversion".
- ETSI EN 300 392-3-1: "Terrestrial Trunked Radio (TETRA); Voice plus Data (V+D); Part 3: Interworking at the Inter-System Interface (ISI); Sub-part 1: General design".
- ETSI EN 300 392-3-2: "Terrestrial Trunked Radio (TETRA); Voice plus Data (V+D); Part 3: Interworking at the Inter-System Interface (ISI); Sub-part 2: Additional Network Functions Individual Call (ANF-ISIIC)".
- ETSI EN 300 392-3-3: "Terrestrial Trunked Radio (TETRA); Voice plus Data (V+D); Part 3: Interworking at the Inter-System Interface (ISI); Sub-part 3: Additional Network Functions Group Call (ANF-ISIGC)".

---

## History

<b>Document history</b>		
Edition 1	September 1999	Public Enquiry PE9959: 1999-09-15 to 2000-01-14
	February 2003	Converted into an EN between Public Enquiry and Vote
V1.1.0	April 2003	Vote V 20030627: 2003-04-28 to 2003-06-27
V1.1.1	July 2003	Publication